



VENOM HIGH SPEEDS

www.usviper.com

OWNERS MANUAL

IMPORTANT: READ OWNERS MANUAL CAREFULLY
Please fill out & return your warranty card!

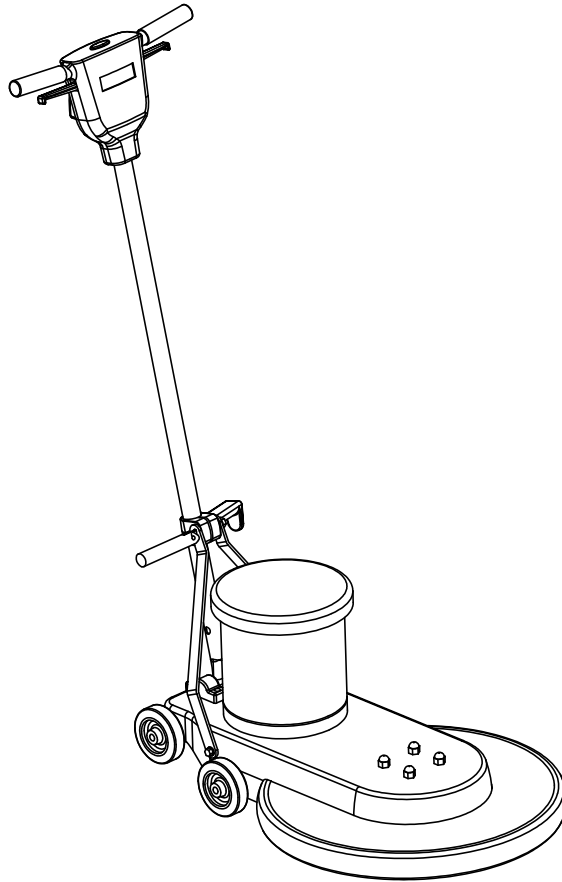

MODEL# VN1500

SERIAL#

**VIPER ...exceptional
value**

REV.06(2014-9)

VF53023MA



TABLE OF CONTENTS

Safety Precautions	3
Machine Operation	4
Machine Maintenance & Storage	4
Handle Release Assembly Instructions	5
Parts Lists	6-10
Wiring Diagram	11



SAFETY PRECAUTIONS

!!! This machine must be grounded!
Grounding provides the path of least resistance for electrical current. To reduce the risk of electrical shock should the machine malfunction, the machine has a special grounding plug. Do not remove the ground pin under any circumstances!

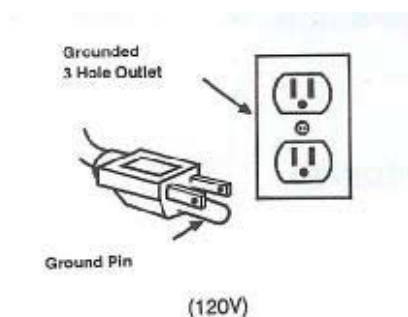

This machine is intended for commercial use. It is constructed for use in an indoor environment and is not intended for any other use. Use only recommended accessories.

All operators shall read, understand and exercise the following safety precautions:

1) Do not operate machine:

- Unless trained and authorized
- Unless you have read and understand operators manual
- In flammable or explosive areas.
- With damaged cord or plug.
- If not in proper operating condition.
- In outdoor areas.
- In standing water.
- With the use of extension cords.

2) Before operating machine:

- Make sure all safety devices are in place and operate properly.

3) When using machine:

- Do not run machine over cord.
- Do not pull machine by cord or plug.
- Do not pull cord around sharp edges or corners.
- Turn power switch to "off " prior to unplugging machine.
- Do not unplug by pulling on the cord.
- Do not stretch cord.
- Do not handle plug with wet hands.
- Keep cord away from heated surfaces.
- Do not pick up burning or smoking debris such as cigarettes, matches or hot ashes.
- Report machine damage or faulty operation immediately.

4) Before leaving or servicing machine:

- Turn off machine.
- Unplug cord from outlet.

5) When servicing machine:

- Unplug cord from outlet.
- Use manufacturer supplied or approved replacement parts.

Operation of High Speed Floor Machine

*** READ OPERATORS MANUAL THOROUGHLY PRIOR TO OPERATING OR SERVICING THIS MACHINE.**

GENERAL USE

1. Remove any obstructions or other obstacles in the area which is to be cleaned.
2. Place the handle in the upright position and tilt machine back until handle rests on the floor
*** Be sure the machine is not plugged into an outlet**
3. Attach the pad to the machine by first unscrewing the male end of the "big mouth" from the flexible pad driver. Place the approved pad on the pad driver, place the male end of the "big mouth" into the center hole of the pad, and tighten the "big mouth" firmly to the pad driver.
4. Place machine back into its upright position.
5. Plug power cord into a grounded outlet.
*** Never use an extension cord in conjunction with the standard power cord.**
6. The handle height may be adjusted by lifting up the compression handle which is located on the right side of the handle tube about 1 foot above floor level. Release the compression handle and adjust handle to safe operating height, then push back down on the compression handle to lock the handle in operating position.
7. To start the machine, press the red safety button on the top of the upper switch housing, and then squeeze either of the operating triggers. (the safety button must be depressed prior to squeezing the operating triggers.)
8. When the machine is in operation, both hands should be placed on the switch housing (upper handle).

9. To stop the machine at any time, simply release the operating trigger(s) and the machine will stop automatically.

MAINTENANCE

To keep the machine performing well for many years, please follow the following maintenance procedures.

*** Always confirm that the machine is unplugged prior to performing any maintenance or repairs.**

1. Unplug machine as soon as you are done using it.
2. Clean the outside of the machine with a mild cleaner.
3. Check power cord for any damage. If damage is detected, replace power cord immediately.
4. Lubricate wheels with a water resistant lubricant once a month.
5. Check machine for loose or missing nuts and bolts, and replace as necessary.
6. If the machine is used in a dusty environment, you may remove the motor cover and blow the motor clean with compressed air. This will ensure proper ventilation, and allow the motor to run cooler.

STORAGE

1. Unplug machine from power source and wrap cord on handle.
2. Tilt machine so the pad is not touching the floor.
3. Store machine in upright position and in a dry area.

Handle Release Assembly Instructions

STEP #1

- 1) Remove nut and spacer from handle bracket assembly.
- 2) Push the two handle brackets backward so they lean against the rear wheel.

STEP #2

- 1) Remove handle clamp blocks with 5mm hex head
- 2) Place handle assembly into handle clamp blocks
- 3) Re-attach the blocks to the base with 5mm hex head

STEP #3

- 1) Make sure actual cord wrap faces to the left of the machine when you are standing behind it.
- 2) Assemble hardware in the following order: spacer, left handle bracket, nylock nut. (do not over tighten nylock nut. Only tighten it enough to hold handle in place when compression lever is in down position)

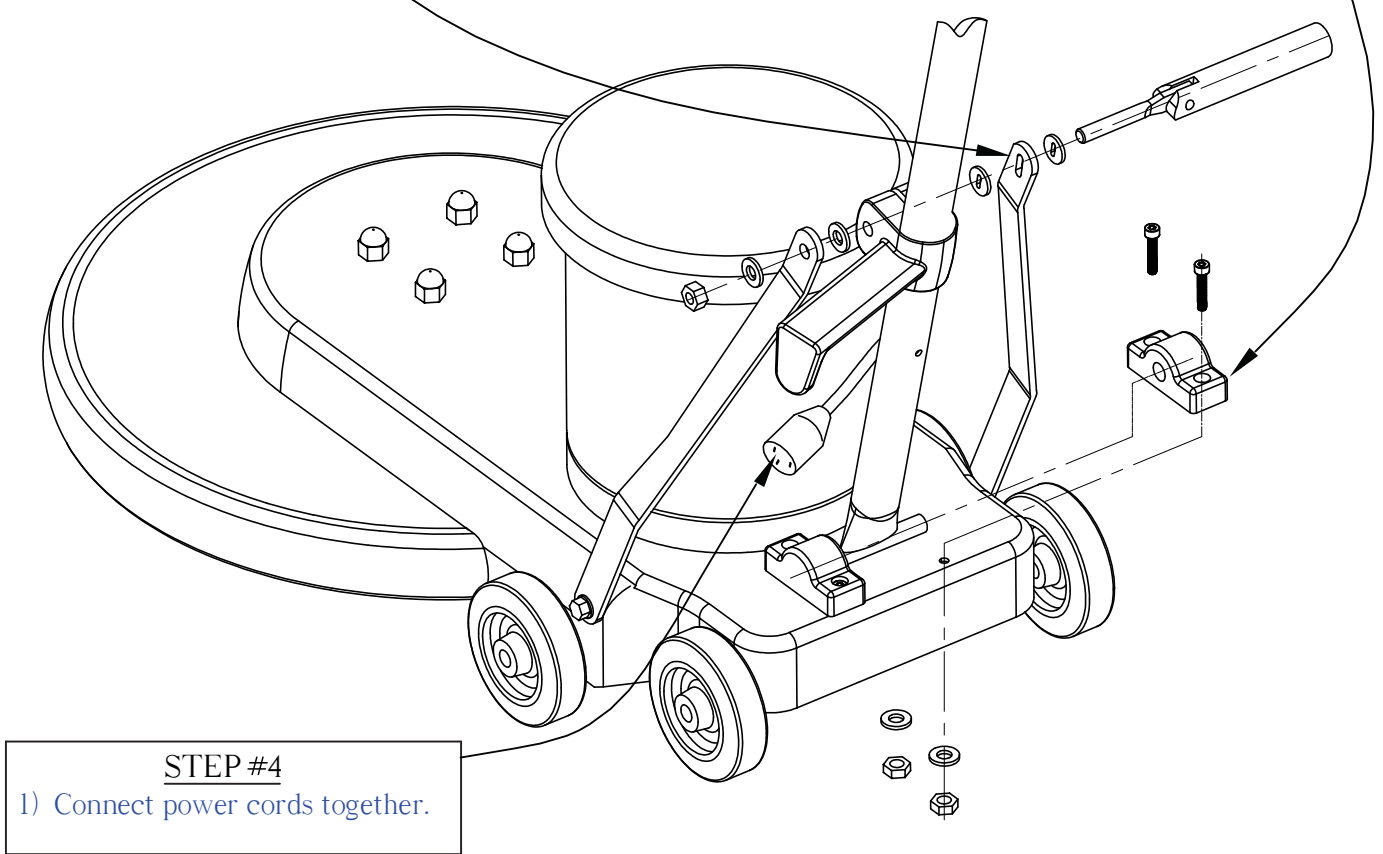

STEP #4

- 1) Connect power cords together.

HANDLE GROUP FOR VN1500

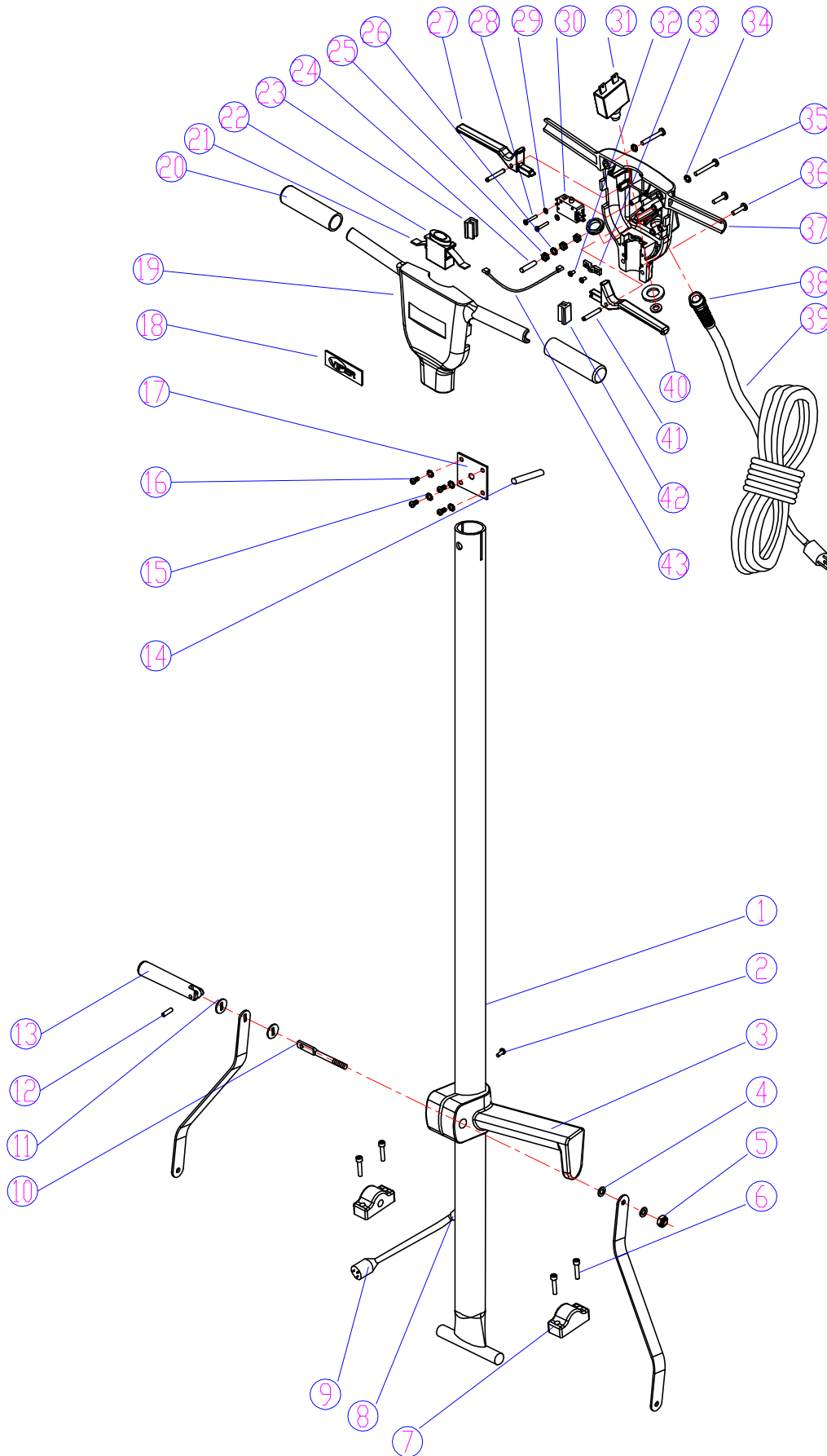

HANDLE GROUP PARTS LIST FOR VN1500

DIA NO	PART NUMBER	DESCRIPTION	NO REQ'D
1	VF53109A	TUBE HANDLE, VN1500	1
2	VF13493	SCREW, M6 x 10, HEX SOCKET	1
3	VF300142	CORD WRAP BLOCK	1
4	VF13517	WASHER, PLAIN, $\Phi 10 \times \Phi 20 \times 2.5$	2
5	VF13504	NUT, M10, NYLON INSERT	1
6	VF14053	HEX SOCKET SCREW, M6x25	4
7	VF30011	CLAMP BLOCK, HANDLE	2
8	VF50120A	GROMMET	1
9	VF45125	CORD, HANDLE, 14/3C	1
10	VF300152	BOLT, HANDLE RELEASE	1
11	VF30018	WASHER, PLAIN, HANDLE RELEASE	2
12	VF30017	SCREW PIN, HANDLE RELEASE	1
13	VF30016	HANDLE RELEASE	1
14	VF13570	PIN	1
15	VF14222	SCREW, M5x12, PH	4
16	VF13604	EXTERNAL TOOTH WASHER, $\Phi 5$	4
17	VF40169	CONNECTION PLATE	1
18	VF47035A	LOGO, VIPER	1
19	VF30101	FRONT COVER	1
20	VF48310	HANDLE GRIP	2
21	GV40218	SPRING, SAFETY BLOCK	1
22	VF46705	SAFETY BLOCK	1
23	VF30109	COVER, LEVELING HANDLE	1
24	VF13526	HEX SOCKET SCREW, M4 x 30	1
25	GT13013	NUT, M4	3
26	VF13527	EXTERNAL TOOTH WASHER, $\Phi 4$	1
27	VF30104	LEVER, RIGHT, SWITCH	1
28	VF14212	SCREW, M3x25, PH	2
29	VF13511	WASHER, LOCK, INTERNAL TOOTH	2
30	VF44203	SWITCH ASSY	1
31	VF99010C	CIRCUIT BREAKER, 17AMPS	1
32	VV13661	SCREW, M4x12, PH	22
33	VF48309	CLAMP BLOCK, CORD, HANDLE	1
34	VF13528	EXTERNAL TOOTH WASHER, $\Phi 6$	2
35	VF14218	SCREW, M6x45, PH	2
36	VF14223	SCREW, M6x25, PH	2
37	VF30102	REAR COVER, HANDLE	1
38	AS22009	STRAIN RELIEF, CORD, POWER SUPPLY	1
39	VF45119	CORD, POWER SUPPLY	1
40	VF30103	LEVER, LEFT, SWITCH	1
41	VF48306	PIN	2
42	VF53111	COVER, LEVER, SOLUTION	1
43	VF45124A	JUMP WIRE	1

BASE GROUP FOR VN1500

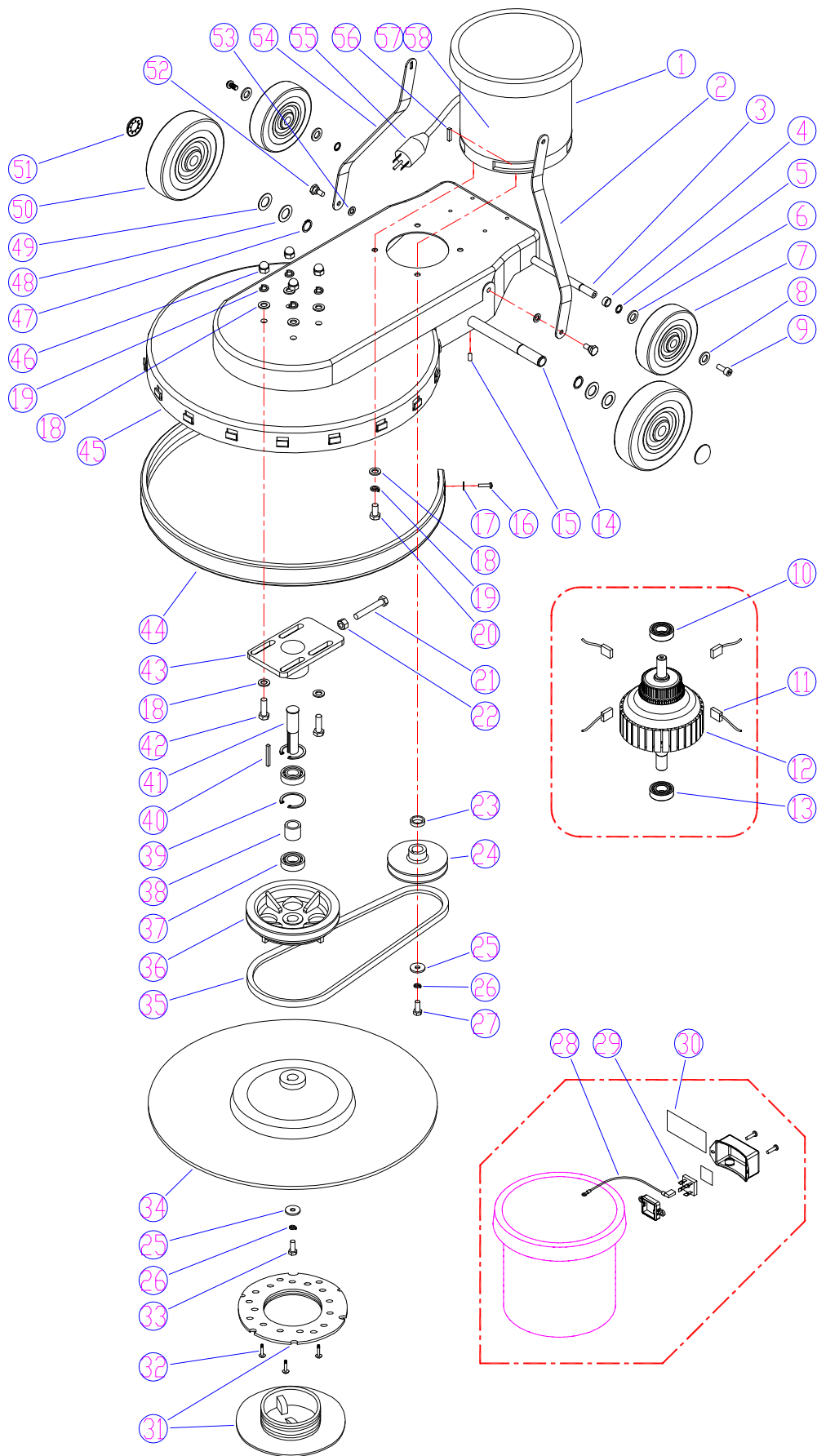

BASE GROUP PARTS LIST FOR VN1500

DIA NO	PART NUMBER	DESCRIPTION	NO REQ'D
1	ZD41000C	MOTOR, 120V	1
2	VF53112	BRACKET, LEFT (New Release Mechanism Serial # 301+)	1
	AS1212A03	BRACKET, LEFT (Original Release Mechanism)	1
3	VF53104	AXLE, TRANSPORT	1
4	VF53106	SPACER, WHEEL, TRANSPORT	1
5	VF13520	RETAINING RING, EXTERNAL, $\Phi 12$	2
6	VF50119	WAVING WASHER, $\Phi 12$	2
7	VF48202	WHEEL, 5"	2
8	VF13666	WASHER, PLAIN, $\Phi 12$	2
9	VF44012	SCREW, M5x12.7	2
10	ZD40225	BEARING, 6203Z	1
11	VF99926-2	CARBON BRUSH	4
12	ZD41200A	SHAFT & ROTOR ASSEMBLY	1
13	ZD40226	BEARING, 6004Z	1
14	VF52010R	FRONT AXLE	1
15	VF13523	SCREW, FLAT, M6X8	2
16	VA13474	SCREW, M5x16, PH	2
17	VF13474A	WASHER, PLAIN, $\Phi 5 \times \Phi 16$	2
18	VF13517	WASHER, PLAIN, $\Phi 10$	12
19	VF13518	WASHER, LOCK, $\Phi 10$	8
20	VF13497	SCREW, 3/8"-16, HEX	4
21	VF14009	SCREW, M10x65, HEX	1
22	VF14005	NUT, M10, HEX	1
23	VF52008	SPACER, DRIVING PULLEY	1
24	VF52009G	DRIVING PULLEY	1
25	VF52021	WASHER, PLAIN, $\Phi 8 \times \Phi 30 \times 5$	2
26	VF13519	WASHER, LOCK, $\Phi 8$	2
27	VF14008	SCREW, 5/16"-18, HEX	1
28	ZD41313	JUMP WIRE	1
29	VF44204	RECTIFIER	1
30	VF54029	DECAL	1
31	VF99003A	BIG MOUTH	1
32	VA13484	ST4x12, PH	3
33	GT13018	SCREW, M8x30	1
34	VF99024D	PAD HOLDER	1
35	VF14079B	VEE BELT	1
36	VF52004A	DRIVEN PULLEY	1
37	VF14075	BEARING, 6004 2RS	2

BASE GROUP PARTS LIST FOR VN1500

DIA NO	PART NUMBER	DESCRIPTION	NO REQ'D
38	VF52006	SPACER, BEARING	1
39	VF14003	RETAINING RING, INTERNAL, Φ 42	2
40	VF52001	KEY, DRIVEN SHAFT	1
41	VF52005	DRIVEN SHAFT	1
42	VF14007	SCREW, M10x32, HEX	4
43	VF52007	MOUNTING PLATE, DRIVEN SHAFT	1
44	AS321203	BUMPER, FRAME	1
45	VF53101	FRAME	1
46	VF14059	CAP NUT, M10	4
47	VF14004	RETAINING RING, EXTERNAL, Φ 19	2
48	VF50123	WASHER, Φ 19	2
49	VF47027	WAVING WASHER, Φ 19	2
50	VF47055	WHEEL, 160MM	2
51	VA96851	CAP, FRONT AXLE	2
52	VF53107	HEX SCREW, BRACKET	2
53	VF13514	WASHER, PLAIN, Φ 8x Φ 16	2
54	VF531131	BRACKET, RIGHT (New Release Mechanism Serial # 301+)	1
	AS1212A07	BRACKET, RIGHT (Original Release Mechanism)	1
55	VF999794	PIGTAIL CORD	1
56	ZD40205	KEY, MOTOR	1
57	VF41079	LOGO, VIPER	1
58	VF53110	SILVER LABEL	1

Wiring Diagram

VN1500

