

HIGH SPEED BURNISHER

OWNERS MANUAL

IMPORTANT: READ OWNERS MANUAL CAREFULLY

Please fill out & return your warranty card!

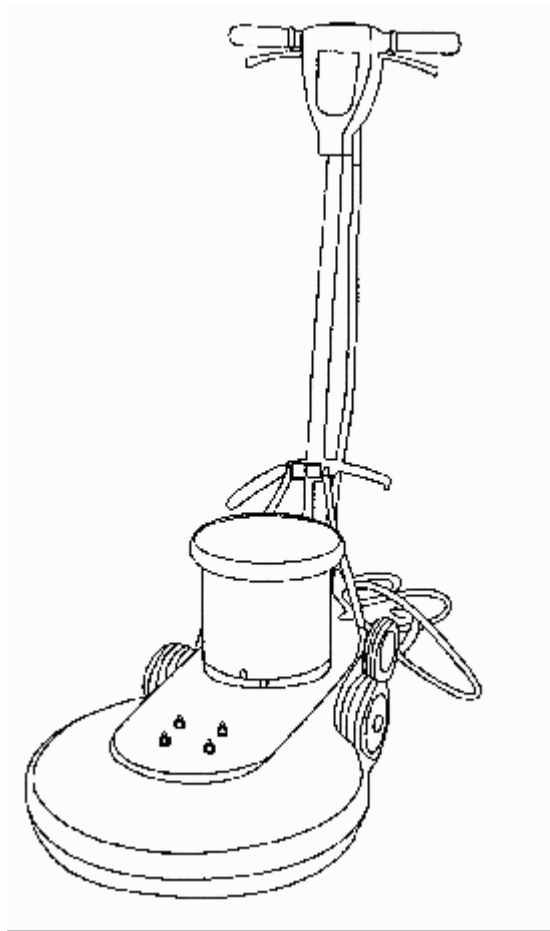

MODEL# TP1500

SERIAL# _____

REV.00(09-08)
VF53023TP

TABLE OF CONTENTS

Safety Precautions	3
Machine Operation	4
Machine Maintenance & Storage	4
Handle Release Assembly	5
Parts Lists	6-10
Wiring Diagram	11

SAFETY PRECAUTIONS

!!! This machine must be grounded!
Grounding provides the path of least resistance for electrical current. To reduce the risk of electrical shock should the machine malfunction, the machine has a special grounding plug. Do not remove the ground pin under any circumstances!

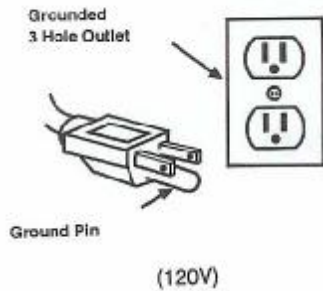

This machine is intended for commercial use. It is constructed for use in an indoor environment and is not intended for any other use. Use only recommended accessories.

All operators shall read, understand and exercise the following safety precautions:

- 1) Do not operate machine:
 - Unless trained and authorized.
 - Unless you have read and understand operators manual.
 - In flammable or explosive areas.
 - With damaged cord or plug.
 - If not in proper operating condition.
 - In outdoor areas.
 - In standing water.
 - With the use of extension cords.

- 2) Before operating machine:

- Make sure all safety devices are in place and operate properly.

- 3) When using machine:

- Only use approved burnishing pads.
- Do not run machine over cord.
- Do not pull machine by cord or plug.
- Do not pull cord around sharp edges or corners.
- Ensure the dust collection bag is in place and is tightly sealed to the machine.
- Turn power switch to "off " prior to unplugging machine.
- Do not unplug by pulling on the cord.
- Do not stretch cord.
- Do not handle plug with wet hands.
- Keep cord away from heated surfaces.
- Do not pick up burning or smoking debris such as cigarettes, matches or hot ashes.
- Report machine damage or faulty operation immediately.

- 4) Before leaving or servicing machine:

- Turn off machine.
- Unplug cord from outlet.

- 5) When servicing machine:

- Unplug cord from outlet.
- Use manufacturer supplied or approved replacement parts.



To avoid electrical shock, please replace the power cord immediately if any damage is being detected. The replacement must be performed only by an authorized person .

Operation of Speed Floor Machines

*** READ OPERATORS MANUAL THOROUGHLY PRIOR TO OPERATING OR SERVICING THIS MACHINE.**

GENERAL USE

1. Remove any obstructions or other obstacles in the area which is to be cleaned.
2. Place the handle in the upright position and tilt machine back until handle rests on the floor
*** Be sure the machine is not plugged into an outlet**
3. Attach the pad to the machine by first unscrewing the male end of the "big mouth" from the flexible pad driver. Place the approved pad on the pad driver, place the male end of the "big mouth" into the center hole of the pad, and tighten the "big mouth" firmly to the pad driver.
4. Place machine back into its upright position.
5. Plug power cord into a grounded outlet.
*** Never use an extension cord in conjunction with the standard power cord.**
6. The handle height may be adjusted by lifting up the compression handle which is located on the right side of the handle tube about 1 foot above floor level. Release the compression handle and adjust handle to safe operating height, then push back down on the compression handle to lock the handle in operating position.
7. To start the machine, press the red safety button on the top of the upper switch housing, and then squeeze either of the operating triggers. (the safety button must be depressed prior to squeezing the operating triggers.)
8. When the machine is in operation, both hands should be placed on the switch housing (upper handle).

9. To stop the machine at any time, simply release the operating trigger(s) and the machine will stop automatically.

MAINTENANCE

To keep the machine performing well for many years, please follow the following maintenance procedures.

*** Always confirm that the machine is unplugged prior to performing any maintenance or repairs.**

1. Unplug machine as soon as you are done using it.
2. Clean the outside of the machine with a mild cleaner.
3. Check power cord for any damage. If damage is detected, replace power cord immediately.
4. Lubricate wheels with a water resistant lubricant once a month.
5. Check machine for loose or missing nuts and bolts, and replace as necessary.
6. If the machine is used in a dusty environment, you may remove the motor cover and blow the motor clean with compressed air. This will ensure proper ventilation, and allow the motor to run cooler.

STORAGE

1. Unplug machine from power source and wrap cord on handle.
2. Tilt machine so the pad is not touching the floor.
3. Store machine in upright position and in a dry area.

Handle Release Assembly Instructions

STEP 1

- 1) Remove nut and spacer from handle bracket assembly.
- 2) Push the two handle brackets forward so they lean against the motor.

STEP 2

- 1) Remove handle clamp blocks with 5mm hex head
- 2) Place handle assembly into handle clamp blocks
- 3) Re-attach the blocks to the base with 5mm hex head

STEP 3

- 1) Place cord wrap assembly (2 pieces) in place, and snug them together with 6mm hex bolt. (actual cord wrap faces to the left of the machine when you are standing behind it)
- 2) Assemble hardware in the following order spacer, left handle bracket, nylock nut. (do not over tighten nylock nut, Only tighten it enough to hold handle in place when compression lever is in down position)

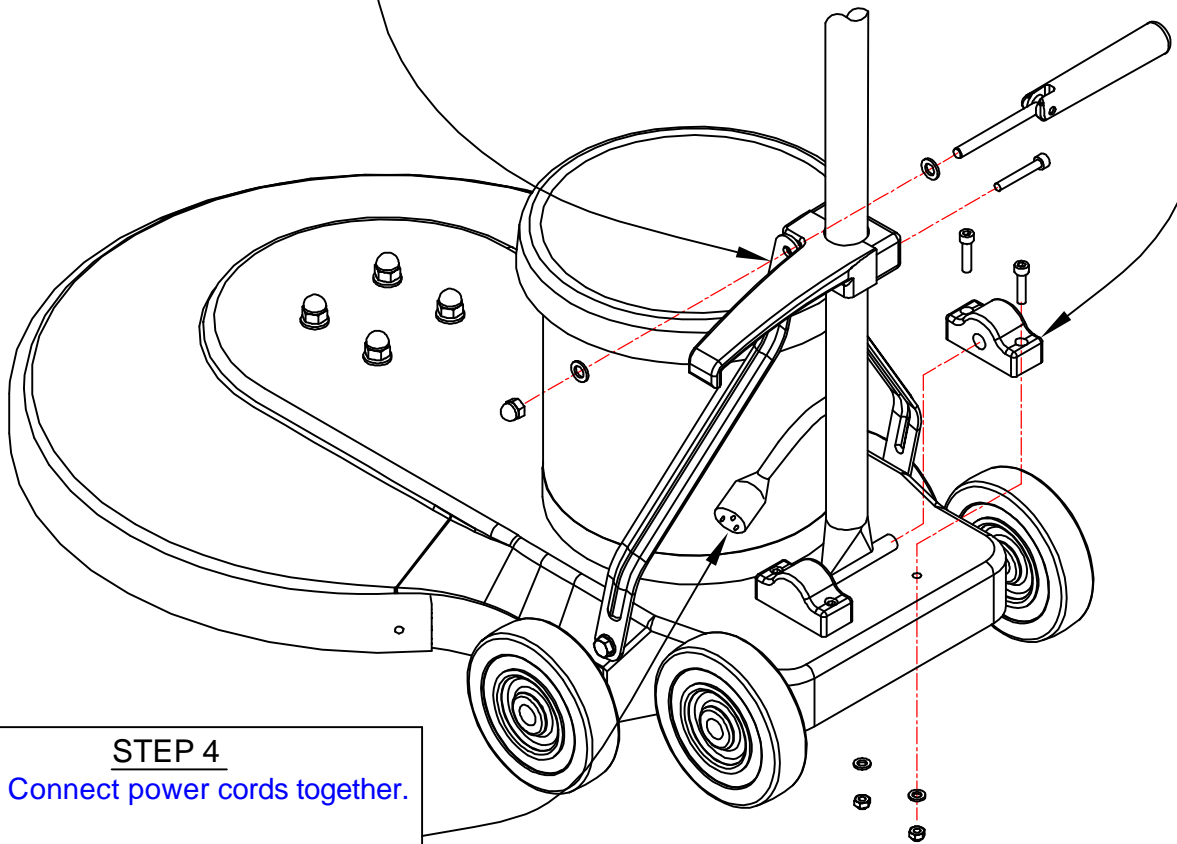

STEP 4

- 1) Connect power cords together.

HANDLE GROUP

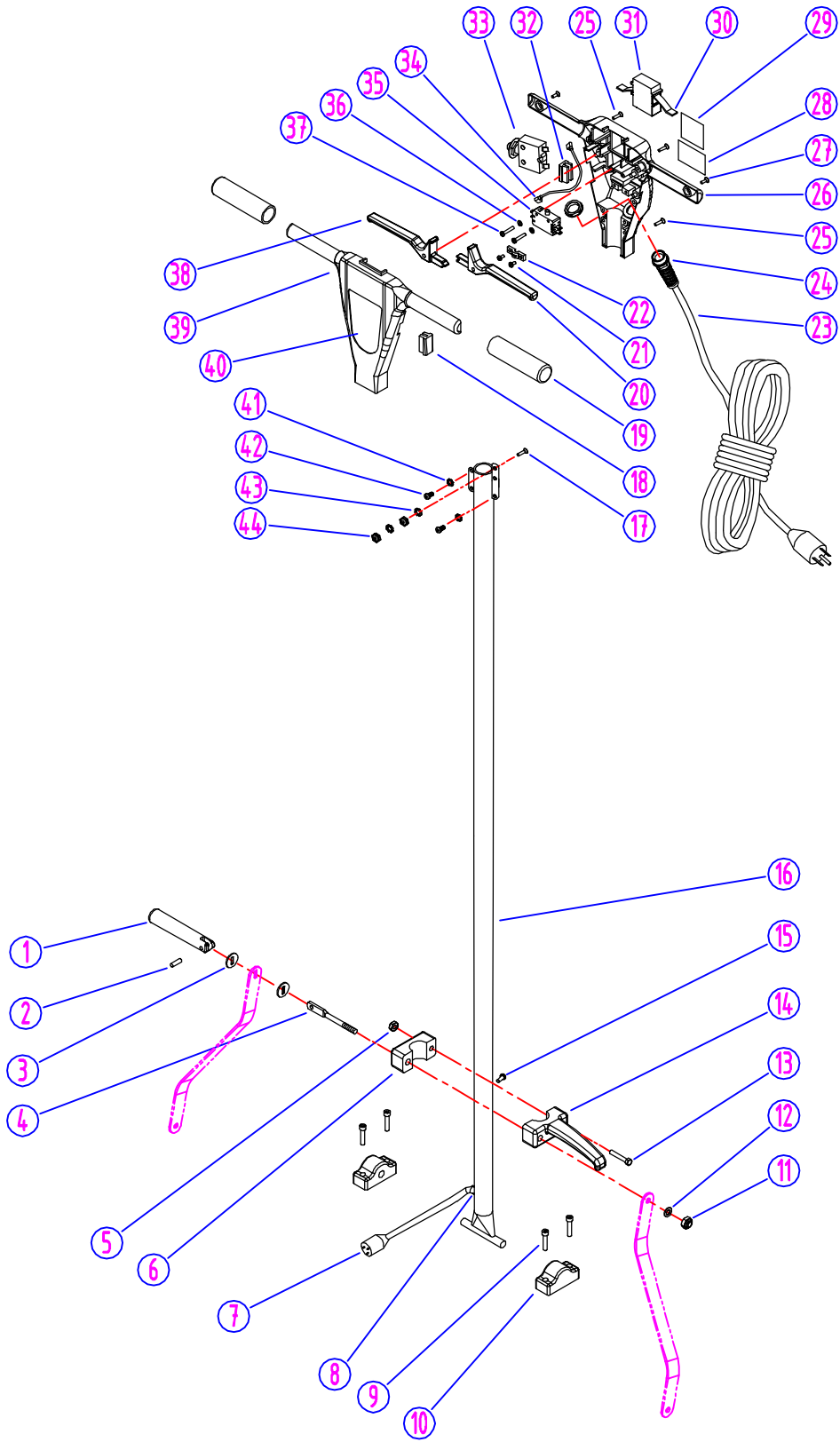

HANDLE GROUP PARTS LIST

DIA NO	PART NUMBER	DESCRIPTION	NO REQ'D
1	VF30016	HANDLE RELEASE	1
2	VF30017	SCREW PIN, HANDLE RELEASE	1
3	VF30018	WASHER, PLAIN, HANDLE RELEASE	2
4	VF30015	BOLT, HANDLE RELEASE	1
5	VF13503	NUT, M8, NYLON INSERT	1
6	VF30014	COVER, HOOK, CABLE	1
7	VF45120	CORD, HANDLE, 14/3C	1
8	VF50120	GROMMET	1
9	VF14053	HEX SOCKET SCREW, M6x25	4
10	VF30011BD	CLAMP BLOCK, HANDLE	2
11	VF13504	NUT, M10, NYLON INSERT	1
12	VF13517	WASHER, PLAIN, ϕ 10x ϕ 20x2.5	1
13	VF14114	SCREW, M8 x 55, HEX	1
14	VF30013	HOOK, CABLE	1
15	VF13493	SCREW, M6x10, HEX SOCKET	1
16	AS321207	TUBE HANDLE	1
17	AS22002	SCREW, M5x16	1
18	GV40238H	COVER, LEVER, SOLUTION	1
19	VF48310	HANDLE GRIP	2
20	AS22005S	LEVER, LEFT, SWITCH	1
21	VV13661	SCREW, M4x12	2
22	VF48309	CLAMP BLOCK	1
23	VF45119	CORD, POWER SUPPLY	1
24	AS22009	STRAIN RELIEF, CORD, POWER SUPPLY	1
25	GT13009	SCREW, M5x30	5
26	AS312209	REAR COVER, HANDLE	1
27	GT13008	SCREW, M5x20	2
28	VF52024TP	SERIAL TAG	1
29	VF40994	READ MANUAL LABEL	1
30	GV40218	SPRING, SAFETY BUTTON	1
31	GV40209	SAFETY BOTTON	1
32	AS312203	COVER, LEVELING HANDLE	1
33	VF99010C	CIRCUIT BREAKER, 17AMPS	1
34	VF45124	JUMP WIRE	1
35	VF99023	SWITCH ASSY	1
36	VF13511	WASHER, LOCK, INTERNAL TOOTH	2
37	VF14212	SCREW, M3x25	2
38	AS22004S	LEVER, RIGHT, SWITCH	1
39	AS312208	FRONT COVER, HANDLE	1
40	GV40226B	LABEL	1
41	VF13604	EXTERNAL TOOTH WASHER, ϕ 5	4
42	VF14222	SCREW, M5x12	4
43	AS22003	TOOTH WASHER, ϕ 5	2
44	VV13633	NUT, M5	2

BASE GROUP

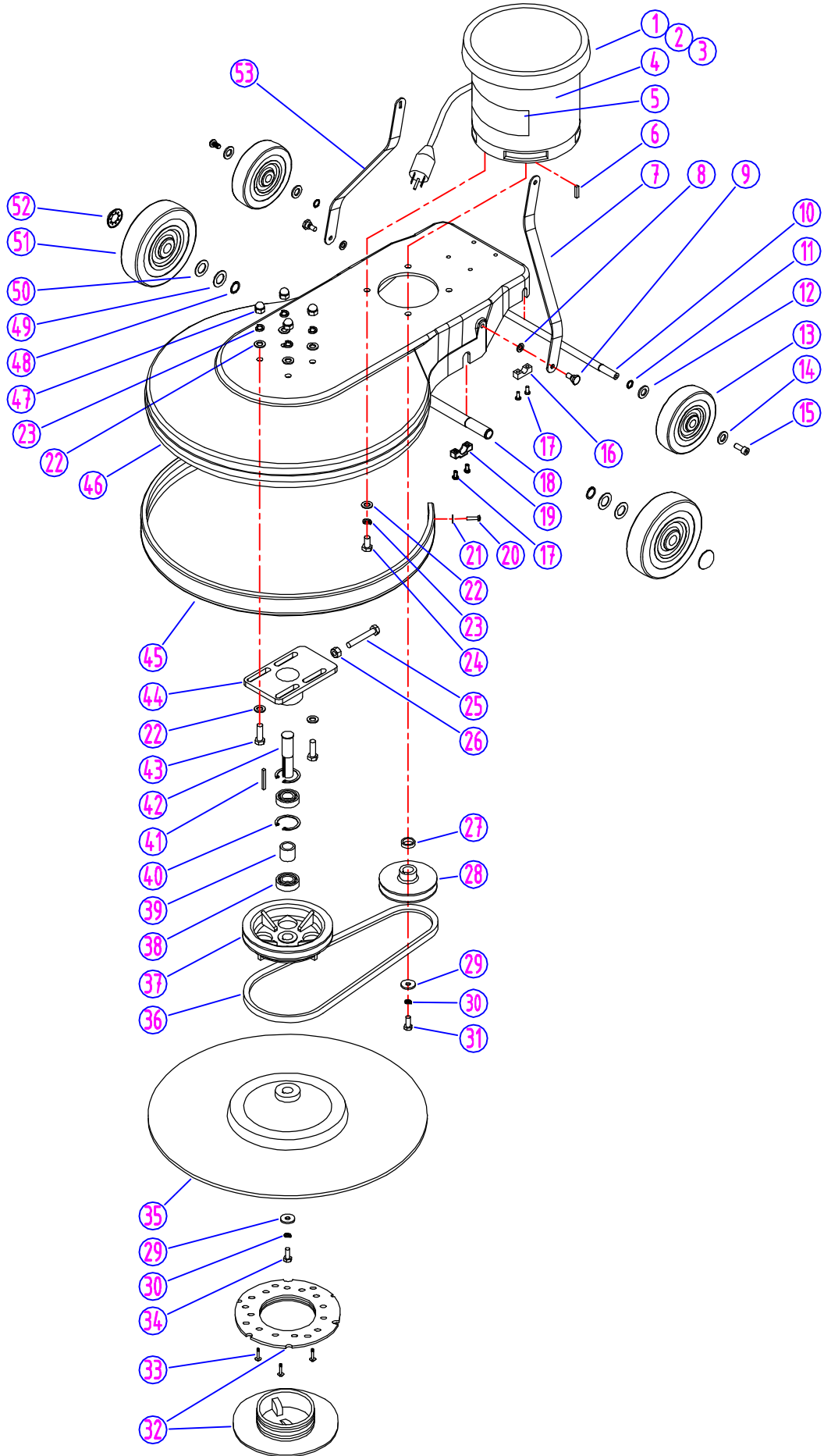

BASE GROUP PARTS LIST

DIA NO	PART NUMBER	DESCRIPTION	NO REQ'D
1	ZD41000C	MOTOR,120V	1
2	VF99926-2	CARBON BRUSH	1
3	VF99926-1	RECTIFIER	1
4	VF53110	LABEL	1
5	VF41079TP	LABEL, LOGO	1
6	VF99924	KEY, MOTOR	1
7	VF53112	BRACKET, LEFT	1
8	VF13514	WASHER, PLAIN, ϕ 8x ϕ 16	2
9	VF53107	HEX SCREW, BRACKET	2
10	VF52011A	AXLE, TRANSPORT	1
11	VF13520	RETAINING RING, EXTERNAL, ϕ 12	2
12	VF50119	WAVING WASHER, ϕ 12	2
13	VF48202	WHEEL, 5"	2
14	VF13666	WASHER, PLAIN, ϕ 12	2
15	VF44012	SCREW, M5 x 12.7	2
16	GV40235	CLAMP BLOCK, AXLE	2
17	VV13621	SELF-TAPPING SCREW, ST5x20	8
18	VF52010R	FRONT AXLE	1
19	VF47038	CLAMP BLOCK, AXLE	2
20	VA13474	SCREW, M5x16	2
21	VF13474A	WASHER, PLAIN, ϕ 5x ϕ 16	2
22	VF13517	WASHER, PLAIN, ϕ 8	12
23	VF13518	WASHER, LOCK, ϕ 8	8
24	VF13497	SCREW, 3/8"-16	4
25	VF14009	HEX SCREW, M10x65	1
26	VF14005	NUT, M10	1
27	VF52008	SPACER	1
28	VF52009G	DRIVING PULLEY	1
29	VF52021	WASHER, PLAIN, ϕ 8x ϕ 30x5	2
30	VF13519	WASHER, LOCK, ϕ 8	2
31	VF14008	SCREW, 5/16"-18, HEX	1
32	VF99003A	BIG MOUTH	1
33	VA13484	ST4x12, PH	3
34	GT13018	SCREW, M8x30, HEX	1
35	VF99024D	PAD HOLDER	1
36	VF14079B	VEE BELT	1
37	VF52004A	DRIVEN PULLEY	1
38	VF14075	BEARING, 6004 2RS	2

BASE GROUP PARTS LIST

DIA NO	PART NUMBER	DESCRIPTION	NO REQ'D
39	VF52006	SPACER, BEARING	1
40	VF14003	RETAINING RING, INTERNAL, ϕ 42	2
41	VF52001	KEY, DRIVEN SHAFT	1
42	VF52005	DRIVEN SHAFT	1
43	VF14007	HEX SCREW, M10x32	4
44	VF52007	MOUNTING PLATE, DRIVEN SHAFT	1
45	AS321203	BUMPER, FRAME	1
46	AS321201TP	FRAME	1
47	VF14059	CAP NUT, M10	4
48	VF14004	RETAINING RING, EXTERNAL, ϕ 19	2
49	VF50123	WASHER, ϕ 19	2
50	VF47027	WAVING WASHER, ϕ 19	2
51	VF47055	WHEEL, 160MM	2
52	VA96851	CAP, FRONT AXLE	2
53	VF53113	BRACKET, RIGHT	1

Wiring Diagram

