

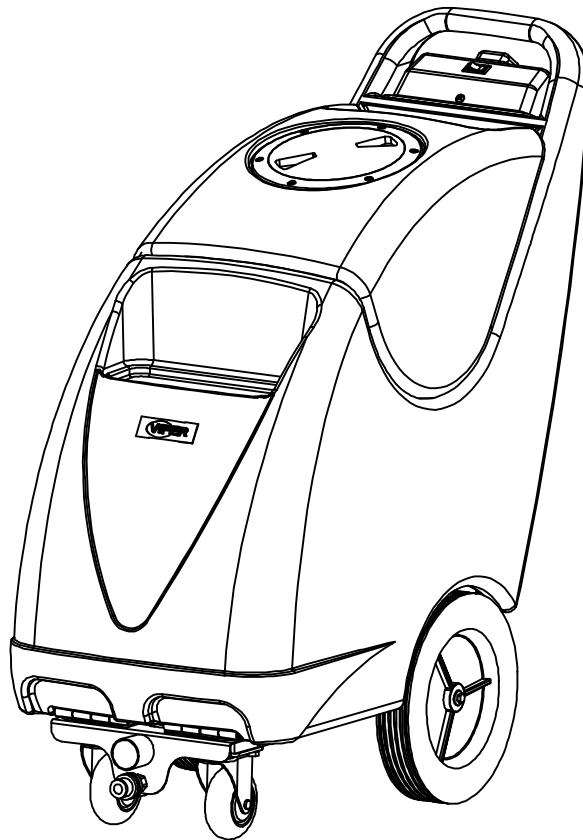

BOX EXTRACTOR

OWNERS MANUAL

IMPORTANT: READ OWNERS MANUAL CAREFULLY
Please fill out&return your warranty card!



MODEL # _____ SL10BOX _____
SERIAL # _____

VIPER NORTH AMERICA
P.O. BOX 104
HAMILTON,MI 49419

[866] 418-4737
[866] 41-VIPER

VIPER...exceptional
value

Rev.00(08-07)

VV66106



CONGRATULATIONS on your purchase of a Viper product, and welcome to the V.I.P. family. We appreciate your business and will do everything in our power to keep you happy with your purchase for many years to come.

As part of the V.I.P. family, you are entitled to the best protection by one of the most comprehensive warranties in the industry.

Thank-you for purchasing Viper products!

Tom Vander Bie, CEO

TABLE OF CONTENTS

Machine Components	3
Safety Precautions	4
Machine Set Up	5
Machine Operation	5-6
Machine Maintenance & Storage	6-7
Troubleshooting	8
Parts Lists	9-15
Wiring Diagram	16

MACHINE COMPONENTS



- 1) Vacuum / pump on/off switch
- 2) Recovery tank lid
- 3) Solution tank fill port
- 4) Pipe
- 5) Accessory tool solution hookup
- 6) Drain hose



SAFETY PRECAUTIONS

GROUNDING INSTRUCTIONS

General – This carped extraction machine shall be grounded while in use to protect the operator from electric shock. The machine is provided with a three-contact grounding type attachment plug to fit the proper grounding type receptacle. The green (or green & yellow) conductor in the cord is the grounding wire. Never connect this wire to other than the grounding pin of the attachment plug.

This machine is for use on a nominal 120-volt circuit and has a grounding plug that resembles the plug illustrated in figure below. Make sure that the machine is connected to an outlet having the same configuration as the plug. No adapter should be used with this machine.

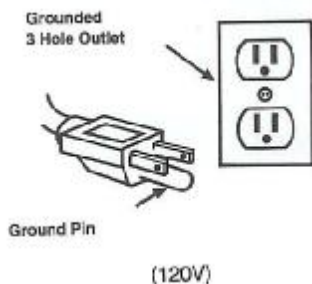

This machine is intended for commercial use. It is constructed for use in an indoor environment and is not intended for any other use. Use only recommended accessories.

All operators shall read, understand and exercise the following safety precautions:

- 1) **Do not operate machine:**
 - Unless trained and authorized
 - Unless you have read and understand operators manual
 - In flammable or explosive areas.
 - With damaged or modified cord or plug.
 - If not in proper operating condition.
 - In outdoor areas.
 - In standing water.
 - Without filters in place.
 - With the use of unapproved extension cords.
- 2) **Before operating machine:**
 - Make sure all safety devices are in place and operate properly.
- 3) **When using machine:**
 - Mix and handle any chemicals according to manufacturer's recommendations
 - Do not run machine over cord.
 - Do not pull machine by cord or plug.
 - Do not pull cord around sharp edges or corners.
 - Do not unplug by pulling on the cord.
 - Do not stretch cord.
 - Do not handle plug with wet hands.
 - Keep cord away from heated surfaces.
 - Do not pick up flammable materials or reactive metals.
 - Report machine damage or faulty operation immediately.
- 4) **Before leaving or servicing machine:**
 - Turn off machine.
 - Unplug power cord from outlet.
- 5) **When servicing machine:**
 - Unplug cord from outlet.
 - Use manufacturer supplied or approved replacement parts.
 - Avoid moving parts. Don't wear loose clothing.

SLIDER EXTRACTOR SETUP

!!! Read operators manual thoroughly prior to operating or servicing this machine!!!

Carefully check the shipping carton for signs of damage. Report any carton damage to carrier immediately.

Check carton contents to ensure carton is complete. Contact your Viper distributor if anything is missing.

Contents:

- Carpet Extractor
- Short “bleeder” vacuum hose
- 50’ extension power cable
- Vacuum and solution hoses

!!! Read operators manual thoroughly prior to operating or servicing this machine!!!

- 1) Using a hose or bucket, fill tank with a maximum of 10 gallons of hot water.



- 2) Add distributor recommended cleaning solution

!!! Do not use flammable liquids or operate machine in or near flammable liquids or vapors!!!

- 3) Connect the supplied extension power cable to the machine. Plug cord into a grounded wall outlet. (see grounding instructions)
- 4) Attach vacuum and solution hoses to appropriate connections on the

machine and your wand.. As you do this, always inspect hoses for cracks or fraying. Do not use if hose are cracked or frayed.

MACHINE OPERATION

PRIOR TO EXTRACTING CARPETS

- 1) Inspect power cable and extension cable for damage. Replace cable if damage is found.
- 2) Vacuum carpet to remove debris prior to extracting carpet.

CARPET EXTRACTING

- 1) Turn on vacuum / pump switch.
- 2) To release spray, simply pull back on your wand trigger.

OPERATING HINTS

- 1) Work away from power outlet and power cable in order to avoid damage to the power cable.
- 2) Continually check for foam buildup in recovery tank. Use a distributor recommended foam control solution.
NOTE: Excessive foam buildup will not activate the float shut-off and may cause damage to the vacuum motor.
- 3) Repeat extraction path on heavily soiled areas.
- 4) When recover of the dirty solution ends, or the solution tank is empty, you must drain the recovery tank. (see TANK DRAINING)

USE OF ACCESSORY TOOLS

NOTE: Prior to cleaning upholstery, be sure to read cleaning instructions provided by the manufacturer.

- 1) Attach vacuum and solution hoses to appropriate connections on the machine.
- 2) Connect (optional) accessory tool to solution and vacuum hoses.

- 3) Turn on vacuum / pump switch.
- 4) Operate accessory tools as needed.
- 5) When cleaning is completed, relieve water pressure from solution lines by turning off vacuum / pump switch and then squeeze trigger for 4 seconds.

DRAINING TANKS

DRAINING SOLUTION TANK

- 1) Connect the “bleeder” vacuum hose (included with machine) to the vacuum inlet.
- 2) Remove the solution tank filter at the fill area and place end of “bleeder” hose into the bottom of the tank.
- 3) Turn on vacuum / pump switch & vacuum out the remaining solution.

DRAINING RECOVERY TANK

- 1) Turn off machine, unplug and remove power cable.
- 2) Unhook drain hose off the back of the machine and remove drain hose stopper.
- 3) Drain dirty solution into floor drain.



- 4) Replace drain hose stopper and reattach hose to back of machine.

MACHINE MAINTENANCE

To keep the machine performing well for many years, please follow the following maintenance procedures.

!!! Always confirm that the machine is unplugged prior to performing any maintenance or repairs!!!

DAILY MAINTENANCE

- 1) When cleaning operation is complete for the day, drain and rinse the recovery tank thoroughly with clean water.
- 2) Remove remaining solution from solution tank.
- 3) Remove float shut-off (ping pong ball in cage) from recovery tank and clean with water.



- 4) The filter located in the solution tank need to be checked and cleaned when dirty in order for it to properly filter debris from the solution tank. If the filter is missing or damaged it must be replaced before the machine is used.
- 5) Clean machine with a nonabrasive cleaner.
- 6) Inspect power cable for any damage. Replace if necessary.

MONTHLY MAINTENANCE

- 1) Flush pump & plumbing with an acetic acid solution to dissolve any chemical buildup.

Mixing Instructions:

- a) Premix 16 oz. of an acetic acid solution with 2 gallons of water and pour into solution tank.
- b) Attach solution hose and wand to machine.
- c) Turn vacuum / pump switch on.

- d) Hold the wand trigger open and direct the flow of solution into the solution tank so that it can recirculate through the entire solution system. After 5 minutes. Remove wand from solution tank and completely empty solution tank through the “bleeder” vacuum hose and drain into the appropriate drain outlet.
- e) Fill solution tank with 3 gallons clean water and completely drain solution tank by holding open the wand trigger and draining into appropriate drain outlet.
- 2) Inspect machine for water leaks.
 - 3) Lubricate wheels with a water resistance lubricant.
 - 4) Check machine for loose or missing nuts, screw and bolts and replace as necessary.

MACHINE STORAGE

- 1) Prior to storing the machine, ensure the solution and recovery tanks are clean and empty of any solution.
- 2) Store machine in upright position in a dry area, with the brush head off the floor.
- 3) Remove recovery tank clear lid to allow for air circulation.

NOTE: If you are storing the machine in an area which can freeze, be sure both tanks and the solution plumbing are empty of all water and dry!



BASIC TROUBLESHOOTING

PROBLEM	CAUSE	SOLUTION
Machine doesn't work	Not plugged in to power source	Plug into a grounded outlet
	Faulty power cable	Contact Viper Distributor
	Faulty extension power cable	Replace with new extension power cable
	Building circuit breaker tripped	Reset circuit breaker
Solution pump not working	Vacuum / pump switch not on	Turn on switch
	Vacuum / pump switch faulty	Contact Viper Distributor
	Faulty solenoid	Contact Viper Distributor
	Faulty solution pump	Contact Viper Distributor
	Pump overheated	Determine cause and allow 30 minutes for pump to cool
	Loose or broken wiring	Contact Viper Distributor
Vacuum motor not working	Vacuum / pump switch not on	Turn on switch
	Vacuum / pump switch faulty	Contact Viper Distributor
	Vacuum motor thermal overload tripped	Check for obstruction and allow 30 minutes to cool
	Faulty vacuum motor	Contact Viper Distributor
	Worn carbon brushes	Contact Viper Distributor
	Loose or broken wiring	Contact Viper Distributor
Poor pick up	Air leaking around clear recovery lid	Ensure recovery lid is firmly tightened
	Clogged float shut-off	Remove float shut-off and clean off debris
	Float shut-off is activated	Drain recovery tank
	Loose drain hose stopper	Ensure stopper is securely in place
	Loose vacuum hose connections	Ensure vacuum hose connections are tight
	Defective vacuum hose	Replace vacuum hose
	Loose vacuum hose cuffs	Ensure cuffs are secure to the hose
	Damaged or loose pickup head shoes	Contact Viper Distributor
	Pulling machine too fast	Slow down cleaning operation
Uneven or no solution spray	Solution tank is empty or low	Fill solution tank
	Vacuum / pump switch not on	Turn on switch
	Dirty or plugged spray tips	Clean or replace spray tips
	Improper spray tip size or spray angle	Contact Viper Distributor
	Worn spray tips	Contact Viper Distributor
	Faulty solution pump	Contact Viper Distributor
	Plugged solution tank filter	Clean or replace filter
	Pinched or kinked solution hose	Check for obstructions and kinks and reroute or replace if needed

SL10BOX

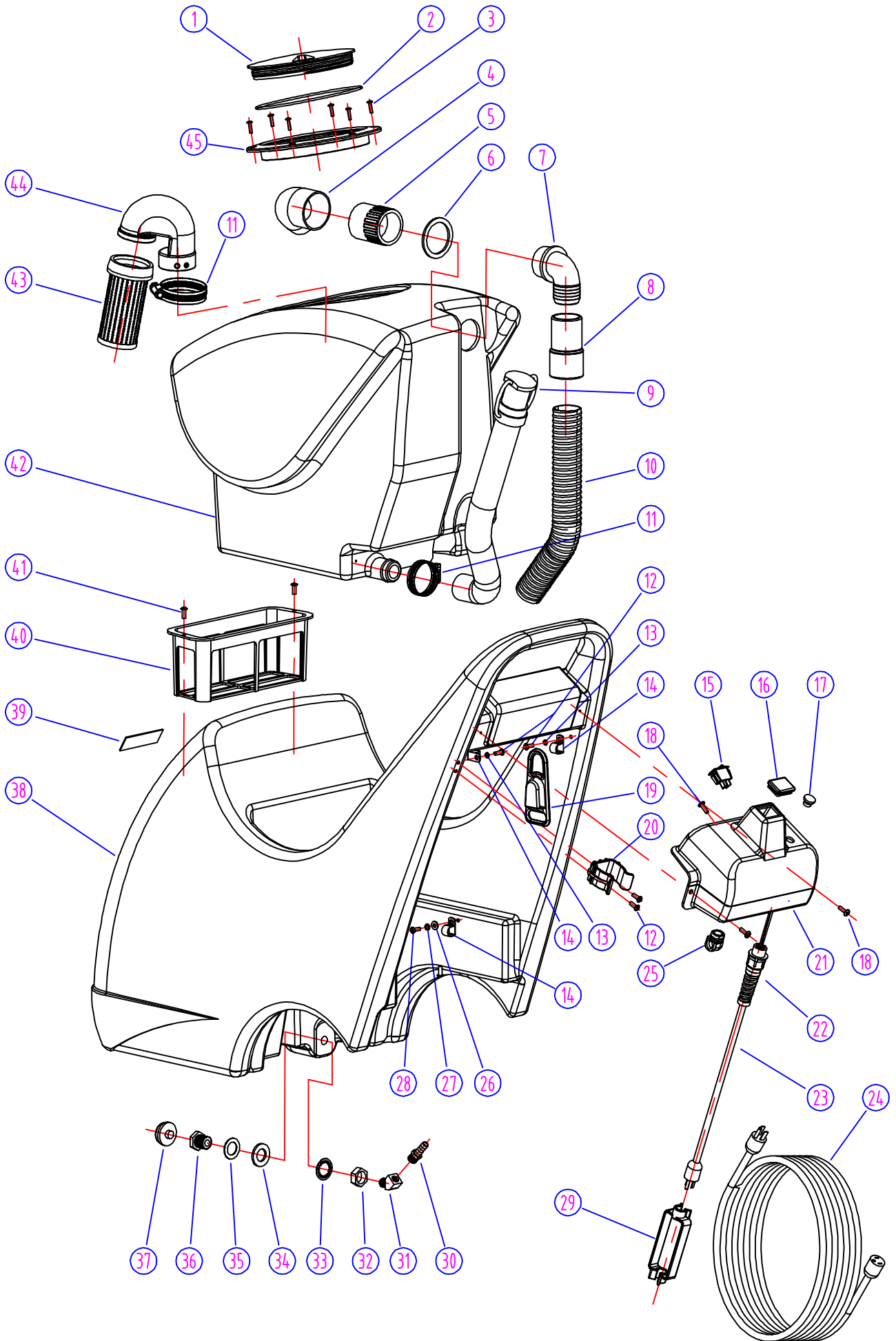

SOLUTION & RECOVERY TANK - SLIDER BOX EXTRACTOR			
DIA NO	PART NUMBER	DESCRIPTION	NO REQ'D
1	VV96001S	LID, CLEAR DOME	1
2	VV60287A	GASKET, CLEAR DOME	1
3	VF13491	SCREW, M4 X 12, SST	6
4	VV67109	TUBE, ELBOW	1
5	VV67301	COUPLER	1
6	VV67302	GASKET, COUPLER	1
7	VV67108	ELBOW	1
8	VF81226	COUPLER, VACUUM HOSE	1
9	VV67705	DRAIN HOSE	1
10	VV67113-1	VACUUM HOSE	1
11	VV10113	HOSE CLAMP, 2"	2
12	VV20509	SCREW, M5 X 10, SST	4
13	VV13601	WASHER, LOCK, SST, M5	2
14	VV50712	CLAMP, CORD	3
15	VV67503	SWITCH	1
16	VV66502	BLOCK, SWITCH	1
17	VV66501	STOPPER	1
18	VF14126	SCREW, HEX HEAD, M5 X 12	3
19	GV40215	CORD WRAP	1
20	VV67111	CLAMP, DRAIN HOSE	1
21	VV67501	SWITCH HOUSING	1
22	VF99008	STRAIN RELIEF	1
23	VV67507	CORD	1
24	VV67116	POWER CORD	1
25	VV67505	BUSHING, CORD, 90°	1
26	GT13032	WASHER, PLAIN, M6 X M16 X 1.5	1
27	VV13607	WASHER, LOCK, SST, M6	1
28	GT13056	SCREW, PAN HEAD, M6 X 16	1
29	VV67105	CONNECTOR	1
30	VV80128	HOSE BARB	1
31	VV80115	ELBOW, STREET, 45°	1
32	VV80125A	NUT, COUPLING	1
33	VV20667	WASHER, LOCK, INTERNAL TOOTH	1
34	VV60509	GASKET, SOLUTION, INTAKE	1
35	VV20276	WASHER, PLAIN	1
36	VV80125	COUPLING	1
37	VV10411	STRAINER, LINE	1
38	VV67101	SOLUTION TANK	1
39	VF80326	LOGO	1
40	VV67107	FILTER	1
41	VA13471	SCREW, ST5 X 10	2
42	VV67102	RECOVERY TANK	1
43	VF81504	FLOAT SHUT-OFF	1
44	VV67305	BEND	1
45	VV96002	BASEMENT, CLEAR DOME	1

SL10BOX

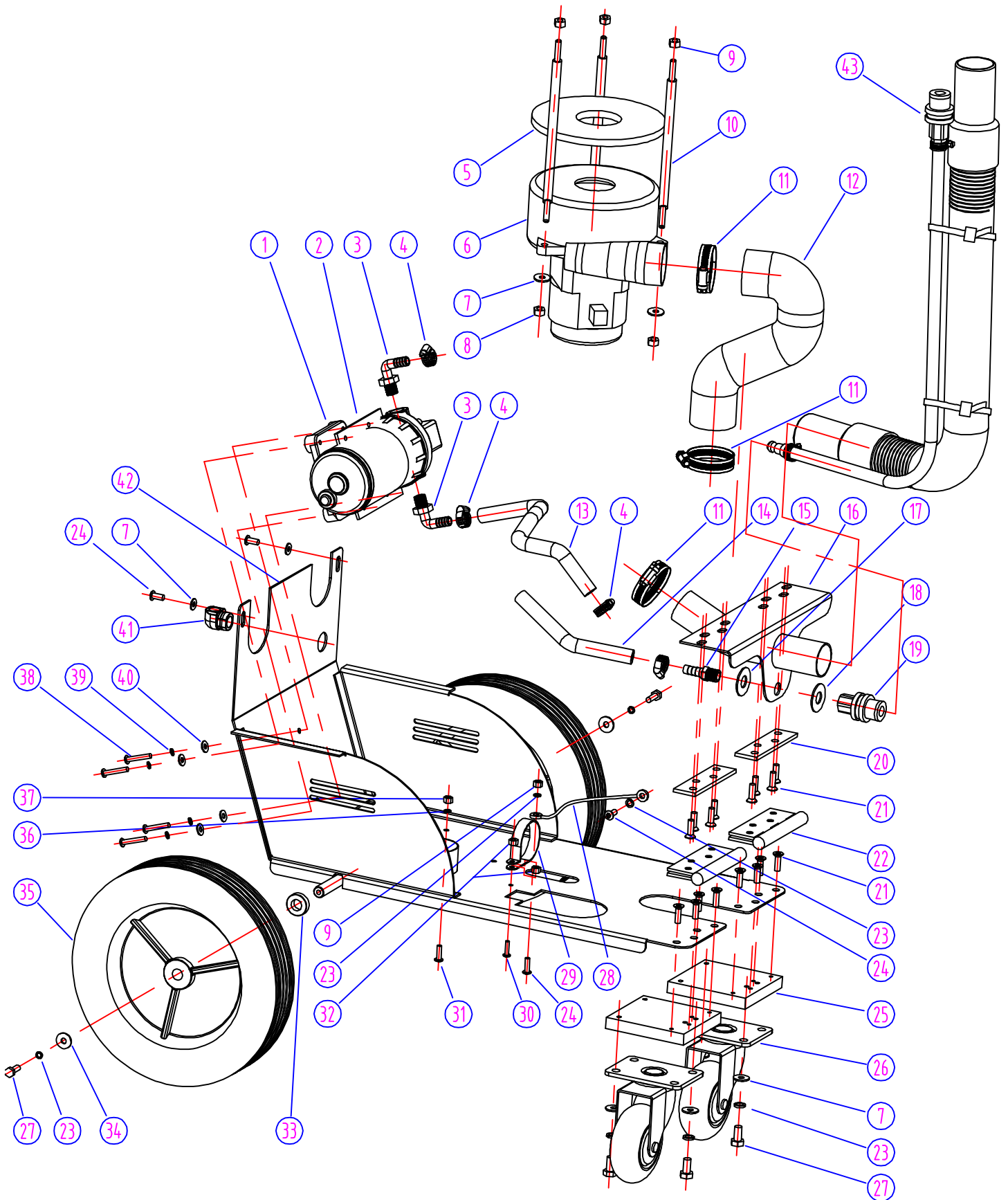

PUMP, VAC, WHEEL ASSEMBLIES - SLIDER BOX EXTRACTOR			
DIA NO	PART NUMBER	DESCRIPTION	NO REQ'D
1	VV67605	PUMP, 115V, 100PSI	1
2	VV67601	MOUNTING FRAME, PUMP	1
3	VV80210	BEND, NYLON, PUMP	2
4	VV10114	CLAMP, HOSE, 3/8"	4
5	VF81503	GASKET, VAC MOTOR	1
6	VV67153	VAC MOTOR, 3-STAGE, 120V	1
7	GT13032	WASHER, SST, PLAIN, M6 X M16 X 1.5	9
8	VF13502	NUT, LOCK, M6	3
9	VF13521	NUT, SST, M6	4
10	VF82310	STUD	3
11	VV10113	CLAMP, HOSE, 2"	3
12	VV67152	EXHAUST HOSE, M48	1
13	VV67117	HOSE, SOLUTION	1
14	VV66115	HOSE, SPRAYING	1
15	VV80128	BARB, HOSE	1
16	VV66101	PIPE ASSY, VAC ELBOW	1
17	VV20274A	WASHER, PLAIN, M14 X M32 X 1.5	1
18	VV20274	WASHER, PLAIN, M13.5 X M32 X 1.5	1
19	VV80208	COUPLER, QUICK CONNECT	1
20	VV67104	SPACER	2
21	VF13512	SCREW, FH, M5 X 15, SST	16
22	VV60406S	HINGE, SST, 4"	2
23	VV13607	WASHER, LOCK, M6	9
24	GT13056	SCREW, SST, PH, M6 X 16	4
25	VV66102	PLATE, 3.5" CASTER	2
26	VA91342	3.5" CASTER	2
27	VF13495	BOLT, M6 X 16, HEX	6
28	VF81028	CABLE	1
29	VV67120	CLAMP	1
30	VA13473	SCREW, RHM, M4 X 16, SST	1
31	VA13635	SCREW, RHM, M5 X 20, SST	1
32	GT13014	NUT, NYLON, INSERT, M4	2
33	VV60113S	WASHER, WHEEL	2
34	VF13551	WASHER, SST, PLAIN, M6 X M22 X 1.5	2
35	VA75004	WHEEL, 10"	2
36	VF13604	WASHER, M5	1
37	VV13633	NUT, SST, M5	1
38	VV13634	SCREW, RHM, M5 X 30, SST	4
39	VV13601	WASHER, LOCK, M5	4
40	VF13474A	WASHER, SST, PLAIN, M5 X M15 X 1	4
41	VV67505	BUSHING, 90°, CORD	1
42	VV66200	BOTTOM PLATE, ASSEMBLY	1
43	VV67702	HOSE ASSEMBLY, VACUUM & SOLUTION	1

SL10BOX

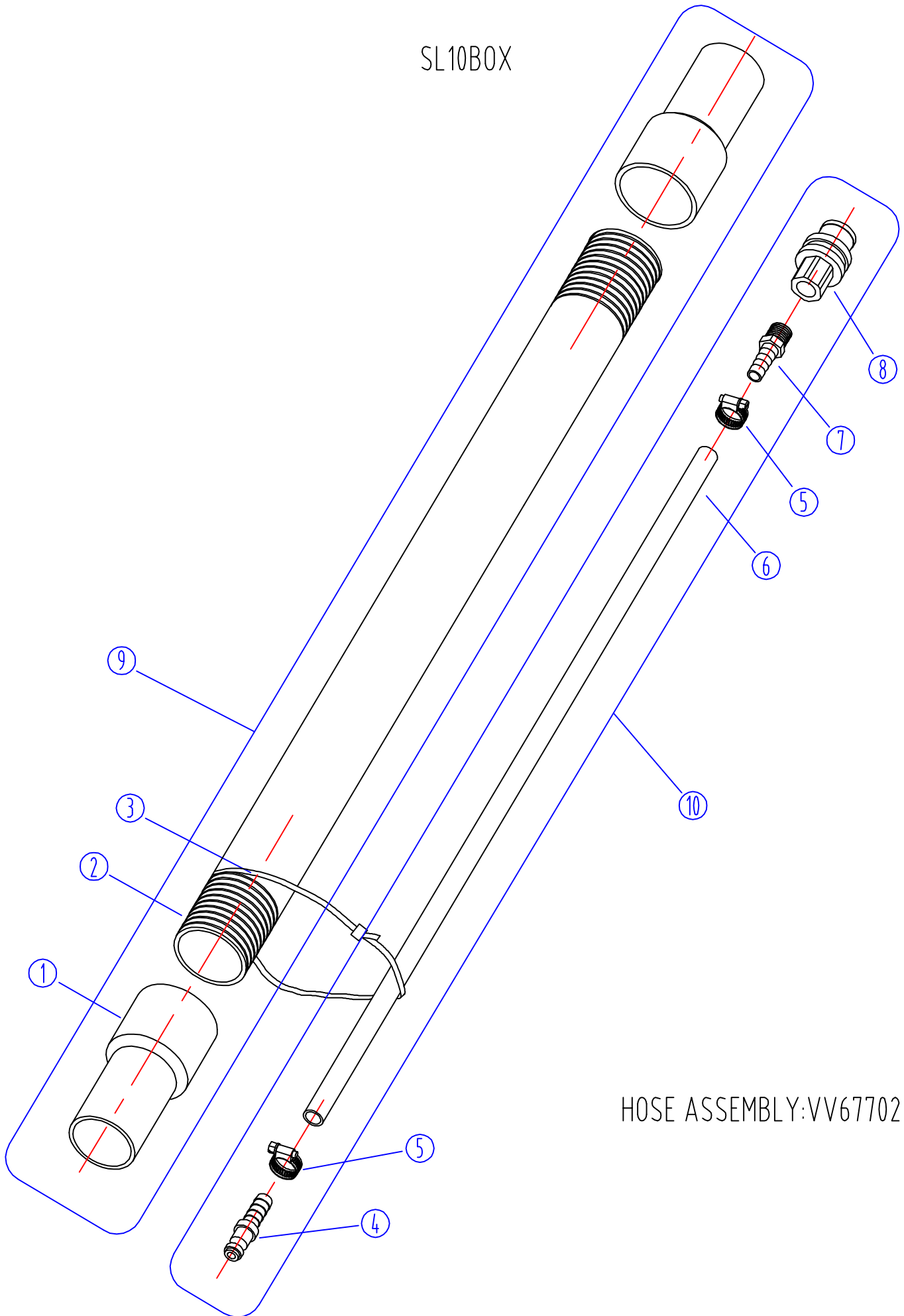

HOSE ASSEMBLY:VV67702

HOSE ASSEMBLIES - SLIDER BOX EXTRACTOR			
DIA NO	PART NUMBER	DESCRIPTION	NO REQ'D
1	VV60220	CUFF, 1 1/2"	2
2	VV67703	HOSE, VACUUM	1
3	VV20652	TIE, CABLE	16
4	VV80241	HOSE BARB, MALE PLUG, SST	1
5	VV10114	CLAMP, HOSE, 3/8", SST	2
6	VV67704	HOSE, SOLUTION, 16' LONG	1
7	VV80128	HOSE BARB	1
8	VV80208	COUPLER, QUICK CONNECT	1
9	VV67703A	VACUUM HOSE ASSEMBLY	1
10	VV67704A	SOLUTION HOSE ASSEMBLY	1

WIRING

