



www.usviper.com

AUTO SCRUBBERS

OWNERS MANUAL

IMPORTANT: READ OWNERS MANUAL CAREFULLY
Please fill out & return your warranty card !



MODEL #

FANG 20HD

SERIAL #

VIPER NORTH AMERICA
P.O. BOX 104
HAMILTON, MI 49419

VIPER...exceptional
value

[866] 418-4737
[866] 41-VIPER

REV.01(04-08)

82816



CONGRATULATIONS on your purchase of a Viper product, and welcome to the V.I.P. family. We appreciate your business and will do everything in our power to keep you happy with your purchase for many years to come.

As part of the V.I.P. family, you are entitled to the best protection by one of the most comprehensive warranties in the industry.

Thank-you for purchasing Viper products!

Tom VanderBie, CEO

TABLE OF CONTENTS

SAFETY PRECAUTIONS	3
MACHINE COMPONENTS	4
MACHINE SET UP	5
MACHINE INSTALLATION	5-6
MACHINE OPERATION	6
TANK DRAINING	7
BATTERY CHARGING	7-8
PREVENTATIVE MAINTENANCE	8-9
MACHINE STORAGE	9
BASIC TROUBLESHOOTING	10
PARTS BREAKDOWNS AND LISTS	11-27
WIRING DIAGRAM	28



SAFETY PRECAUTIONS

This machine is intended for commercial use. It is constructed for use in an indoor environment and is not intended for any other use. Use only with recommended accessories.

All operators shall read, understand and exercise the following safety precautions:

- 1) DO NOT OPERATE MACHINE:**
 - Unless trained and authorized.
 - Unless you have read and understand the operators manual.
 - In flammable or explosive areas.
 - If not in proper operating condition.
 - In outdoor areas.
- 2) BEFORE OPERATING MACHINE:**
 - Make sure all safety devices are in place and operate properly.
- 3) WHEN USING MACHINE:**
 - Go slow on inclines and slippery surfaces.
 - Follow all safety guidelines.
 - Be very careful when using the machine in reverse.
 - Report and fix any damage to machine prior to operating it.
- 4) BEFORE LEAVING OR SERVICING MACHINE:**
 - Stop machine on level ground.
 - Turn machine off.
- 5) WHEN SERVICING MACHINE:**
 - Read operators manual thoroughly prior to operating or servicing this machine.
 - Use manufacturer supplied or approved replacement parts.
 - Secure machine with wheel blocks prior to jacking the machine up.
 - Use approved jack or hoist to safely elevate the machine.

WHEN SERVICING MACHINE: (con't)

- Disconnect batteries prior to working on machine.
- Wear gloves when handling batteries or battery cables.
- Avoid any contact with battery acid.
- Avoid moving parts. Do not wear loose fitting clothing while servicing machine.

WARNING : Batteries emit hydrogen gas. Explosion or fire can result from hydrogen gas. Keep sparks and open flames away! Keep battery compartment open when charging.

WARNING : Flammable materials can cause an explosion or fire. Do not use flammable materials in tanks.

WARNING : Flammable materials or reactive metals can cause explosion or fire. Do not pick up.

MACHINE COMPONENTS

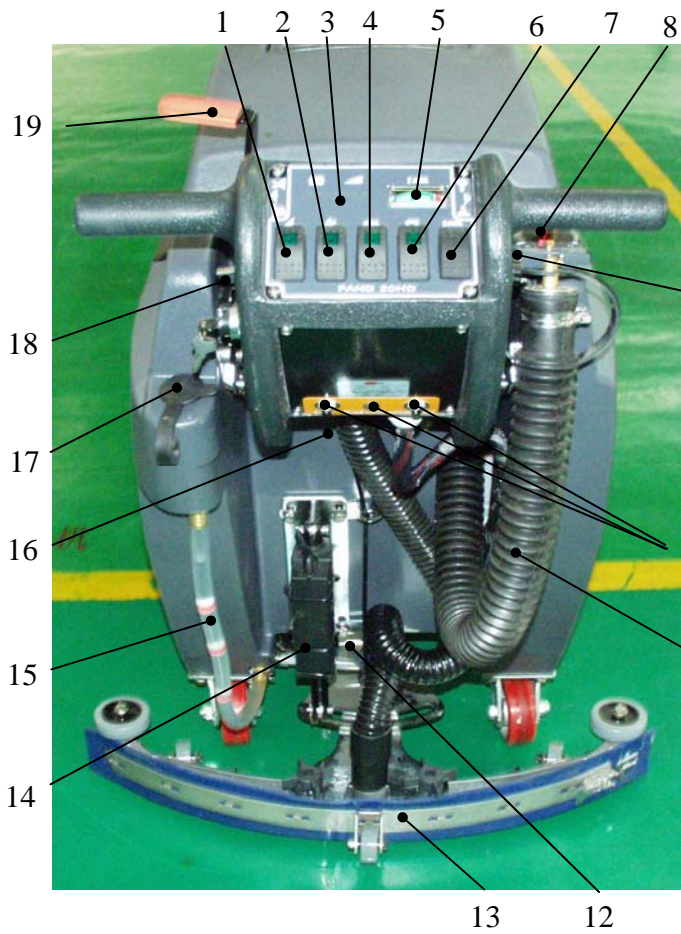

1. Main power ON/OFF switch
2. Vacuum ON/OFF switch
3. Battery level meter
4. Brush ON/OFF switch
5. Brush pressure meter
6. Solution ON/OFF switch
7. Brush pressure UP/DOWN switch
8. Solution control knob
9. Speed control knob
10. Circuit breakers
11. Recovery tank drain hose
12. Squeegee adjustment nut & shaft
13. Squeegee assembly
14. Scrub head actuator
15. Solution tank level sight tube

16. Console adjustment levers
17. Rear solution fill
18. Reverse switch
19. Squeegee lift lever
20. Control housing
21. Operating triggers
22. Solution tank
23. Rear casters
24. Transport wheels
25. Scrub head
26. Scrub head skirt
27. Skirt housing latch
28. Protective rollers
29. Front solution fill
30. Recovery tank
31. Recovery tank lid

MACHINE SET UP & INSTALLATION

UNCRATING MACHINE

Be sure and check packing carton for any damage. Immediately report any damage to carrier. Check contents of package to ensure that the following items are included: Machine, batteries (x2), squeegee assembly, battery charger, and pad driver.

BATTERY CONNECTIONS

The batteries and charger are shipped separately and will need to be installed and connected as shown in the diagram below.

WARNING

: Batteries emit hydrogen gas.

Explosion or fire can result from hydrogen gas. Keep sparks and open flames away! Keep battery compartment open when charging.

1. Be sure power switch is in the “off” position.
2. Open recovery tank to gain access to battery compartment.
3. Carefully place the two batteries into the compartment as shown in figure below. Place the battery brace at the rear of the two batteries. **DO NOT DROP BATTERIES INTO COMPARTMENT!**
4. Connect battery cables to posts in numbered order as shown in drawing below. (RED to POSITIVE and BLACK to NEGATIVE)

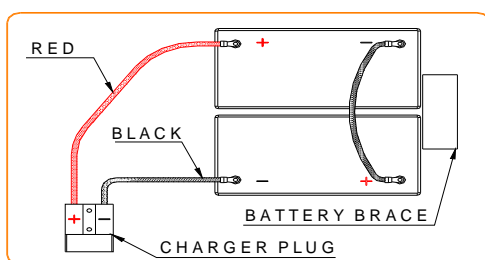

5. Apply a coat or protective spray on the cable connections to prevent battery corrosion.

MACHINE SET UP

PRE-OPERATION CHECKS

1. Sweep or dust mop the surface to be cleaned.

2. Check battery meter to make sure batteries are fully charged. (see BATTERY CHARGING)
3. Check that squeegee is properly installed.
4. Check that brush / pad is properly installed.

INSTALLING PAD DRIVER OR BRUSH

1. Ensure that the machine is turned off
2. Raise the brush head assembly off the floor by pushing on the brush lift button on the control console.
3. Open the swing away skirts to gain access to the brush head assembly.
4. If using a pad driver, first attach the appropriate pad to the pad driver surface.
5. Mount the pad driver or brush to the drive motor hub by lining up the three studs with the three holes in the drive motor hub. Once in the holes, rotate the driver toward the spring clip to lock driver into place.

MOUNTING THE SQUEEGEE

1. Pull back on the squeegee lift lever to raise the squeegee bracket up.
2. Loosen the two knobs on the squeegee and slide the squeegee into the slots at the rear of the squeegee bracket. (the wheels on the squeegee point to the back)
3. Tighten the knobs securely.
4. Secure the vacuum hose on the pick-up tube of the squeegee.



FILLING THE SOLUTION TANK

1. The Fang 20HD can be filled in two different locations:
 - a. Front fill area for use with a hose or a bucket.
 - b. Rear fill area for use with a hose only.
2. Determine which fill area you would like to use to fill the machine with water.
3. Fill solution tank with up to **15 gallons** of water. (water temperature should not exceed 140° F) The clear tube in the back left of the

machine has gallon markers to help determine the water level in the solution tank

HINT

: If you are filling the solution tank with a bucket, make sure the bucket is clean. This will prevent debris from clogging the lines or solenoid.

WARNING

: Do not put any flammable materials into solution tank. This can cause an explosion or a fire. Only use recommended cleaning chemicals. Contact your janitorial supply distributor for recommendations on proper chemicals.

MACHINE OPERATION

WARNING

: Do not operate machine unless you have read and understand this manual.

1. Set control housing to a comfortable operating height by squeezing together the two thumb levers directly underneath the housing. (see machine components, item #16)
2. Lower squeegee assembly to the floor by releasing the lift lever from its locked position. (see machine components, item #19)
3. Lower the brush head assembly to the floor by pushing on the brush lift button on the control console. (see machine components, item #7)
4. Turn main power to “on” position. (see machine components, item #1)
5. Turn vacuum motor switch to “on” position. (see machine components, item #2)
6. Turn the brush motor switch to “on” position. (see machine components, item #4)
 - a. Brushes will not spin until the operating triggers are pulled.
7. Turn the solution switch to “on” position. (see machine components, item #6)
 - a. Solution will not begin to flow until the operating triggers are pulled.
8. To begin scrubbing, pull on one or both of the red operating triggers. (see machine components, item #21) When these triggers are pulled, the brush will begin to spin, the solution will begin to flow, and the machine will propel itself.
9. This machine is self-propelled. The speed can be controlled by a dial located on the right

side of the control housing. (see machine components, item #9)

10. This machine has reverse. In order to activate reverse, there is a toggle switch located on the left side of the control housing. (see machine components, item #18) The toggle switch must be pulled backwards and the red operating triggers must be pressed to activate reverse motion.

HINT

: Do not keep the machine in the same position with the pad / brush spinning, or you could cause damage to the floor.

11. Adjust amount of solution flow by turning the solution control knob. Turn to the right for more solution, or turn left for less solution. (see machine components, item #8)

WHILE OPERATING MACHINE

1. Occasionally look through the clear recovery tank lid to see if there is any foam build-up. If excessive foam is found, add defoamer to the recovery tank.

WARNING

: Foam must not enter the float shut-off screen, or damage can occur to the vacuum motor. Foam will not activate the machines float shut-off device.

2. Occasionally view the clear tube at the back left of the machine to check the amount of cleaning solution that is left in the machine.
3. Occasionally check the battery level meter. (see machine components, item #3) When meter is in the red, recharge the batteries.

WARNING

: When battery meter is in the red, do not continue to operate the machine. Battery damage may result.

4. If the squeegee assembly leaves streaks on the floor, raise the squeegee off the floor and wipe the blades down with a damp cloth.

WARNING

: Do not use your fingers to wipe or remove debris from the blades, as injury may occur.

5. When the solution tank runs empty, turn off the brush switch, solution switch and raise the brush head. Keep the squeegee down and continue to vacuum until all the dirty water is

picked up. (see TANK DRAINING section to learn how to drain recovery and solution tanks)

HINT

: The brush motors are circuit breaker protected to protect them from damage. If a breaker trips, it can't be reset immediately. You must first determine what caused the breaker to trip, and allow the motor to cool down before you can reset the breaker. The breakers are located on the back panel of the control housing.

TANK DRAINING

1. Turn the power off on the machine
2. With the squeegee and brush head in their "up" position, transport machine to approved area for draining tank(s).

DRAINING THE RECOVERY (DIRTY) TANK

HINT

: Anytime scrubbing is completed, or when refilling solution tank, the recovery tank should be drained and cleaned.

WARNING

: If the recovery tank is not drained when the solution tank has been refilled, foam or water may enter the float shut-off mechanism and cause damage to the vacuum motor.

1. Remove the drain hose from the holder, and place the drain hose over the floor drain. Twist off the drain hose plug to begin the draining process. In order to completely empty the recovery tank, hinge open the recovery tank and let it rest on the support stand.
2. Clean the recovery tank after every use. Use a fresh water hose to rinse out the recovery tank. Be careful not to spray water into the float shut-off mechanism.

HINT

- : If you are storing the machine for any period of time, always leave the clear recovery tank lid off the tank so the tank can dry completely and smell fresh.
3. Replace the drain hose plug tightly as soon as you are done draining the tank.

DRAINING THE SOLUTION (CLEAN) TANK

HINT

: Anytime scrubbing operation is completed, the solution tank should be drained and cleaned.

1. Pull down on the clear tube (back left of the machine) to remove it from the hose barb. This will allow the solution to flow freely into a bucket or floor drain.
2. Rinse the solution tank with clean water after every use. This will help prevent chemical buildup and clogging of the solution lines.
3. With clean water in solution tank, turn machine power on, solution switch "on" and pull the operating triggers. This will allow the clean water to flush through and clean the solution plumbing.
4. Once tank is rinsed, flushed and drained, reconnect the clear tube to the hose barb. Be sure the tube is pushed all the way up on the hose barb.

BATTERY CHARGING

WARNING

: Use only approved chargers with the following specifications:

- Automatic shut off circuit
- Deep cycle charging
- Output current of 10 – 20 amps
- Output voltage of 24 volts

HINT

: For the best machine performance, keep batteries charged at all times. Do not let them sit in a discharged condition.

WARNING

: Batteries are dangerous! Batteries emit hydrogen gas and an explosion or fire can result. Keep sparks and fire away from batteries at all times. When charging the machine, make sure the battery compartment is left open.

1. Place charger and machine in a well ventilated area.
2. Turn machine off.
3. Open recovery tank up, exposing battery compartment
4. Check fluid level in each battery cell. Do not charge batteries unless fluid is slightly covering the battery plates. Do not overfill the

batteries. Overfilling may cause the batteries to overflow during charging due to expansion. Replace the caps prior to charging.

5. Plug approved charger into grounded wall outlet before plugging the charger into the machine.
6. Plug charger into red charger receptacle located in the front left of the battery compartment.
7. compartment.



8. Flip up the recovery tank “kick stand” and gently lay the recovery tank down until it rests on the stand.
9. The charger will automatically begin to charge the batteries, and it will automatically shut down once the batteries are fully charged.
10. Upon completion of charging, first unplug the charger from the wall outlet, and then disconnect the charger from the machine.
11. Check the battery level after charging is complete. If fluid level is low, add distilled water to bring the fluid level up to the bottom of the sight tubes. Replace the caps and wipe the batteries down with a towel.

PREVENTATIVE MAINTENANCE

WARNING : Before performing any maintenance on the machine, be sure that the power is turned off, or the batteries are disconnected!

WARNING : Repairs are to be completed by Authorized Service Centers only. Any repairs completed by unauthorized persons will void the warranty.

DAILY MAINTENANCE

1. Remove pad driver / brush and clean with approved cleaner.
2. Drain recovery and solution tanks completely and rinse out with clean water. Visually check the recovery tank for debris and clean out as necessary.
3. Raise squeegee assembly off floor and wipe it down with a damp towel. Be sure to store the squeegee in the up position.
4. Remove the float shut-off assembly and rinse it out with clean water.



5. Clean machine with an approved cleaner and a damp towel.
6. Recharge batteries.

WEEKLY MAINTENANCE

1. Check fluid level in batteries.
2. Check batteries for loose or corroded cables.
3. Keep battery tops clean from corrosion.

MONTHLY MAINTENANCE

1. Check machine for leaks and loose fasteners.
2. Lubricate all grease points and pivot points with silicon spray and approved grease.
3. Place machine over a floor drain. Flush solution system by pouring 3 gallons of hot water and approved alkaline detergent into the solution tank and running machine (with solution control on) for 45 seconds. Turn machine off and let it sit overnight. Then next day, drain the remaining solution and rinse the solution tank out with clean water.

VACUUM MOTOR MAINTENANCE

1. Contact your local Viper Distributor for any motor maintenance.
2. Vacuum motor should have the brushes checked every 250 hours. Brushes should be replaced when they are worn to a length of 10mm or less.

7. Drain the recovery tank and remove the clear on the top of the recovery tank so that it can “breathe” during storage.
8. Drain the solution tank of all fluid.

BATTERY MAINTENANCE

HINT

: For the best machine performance, keep batteries charged at all times. Do not let them sit in a discharged condition.

WARNING

: Batteries are dangerous! Batteries emit hydrogen gas and an explosion or fire can result. Keep sparks and fire away from batteries at all times.

WARNING

: Whenever servicing batteries, be sure to wear protective gloves. Avoid contact with battery acid at all times!

1. Always follow the battery charging directions as outlined in the BATTERY CHARGING section of this manual.
2. Keep battery tops and terminals free from corrosion. A strong solution of baking soda and water is the best way to keep the batteries corrosion free. **DO NOT ALLOW THE BAKING SODA / WATER SOLUTION TO ENTER THE BATTERY CELLS.**
3. Use a wire brush with the baking soda solution to properly clean the battery posts and connections.
4. Check battery connections for wear and loose terminals. Replace if necessary.

MACHINE STORAGE

1. Always store the machine indoors.
2. Always store the machine in a dry area.
3. Always store the machine in its upright position.
4. Always store the machine with the pad driver / brush raised off the floor.
5. Always store the machine with the squeegee assembly raised off the floor.
6. If storing in an area which may reach freezing temperatures, be sure to drain all fluids from the machine prior to storage. Any damage

BASIC TROUBLESHOOTING

PROBLEM	CAUSE	SOLUTION
No power	Bad batteries	Replace batteries
	Batteries need to be charged	Charge batteries (see Battery Charging)
	Loose battery cable	Tighten loose cable(s)
	Batteries not connected properly	Follow battery installation instructions
Brush motor does not run	Bad brush switch	Contact Viper Distributor
	Brush circuit breaker has tripped	Check brush motor for obstructions and reset breaker
	Rectifier has burned out	Contact Viper Distributor
	Bad wiring	Contact Viper Distributor
	Bad brush motor	Contact Viper Distributor
	Carbon brushes worn out	Contact Viper Distributor
Vacuum motor does not run	Bad solenoid	Contact Viper Distributor
	Bad vacuum switch	Contact Viper Distributor
	Bad wiring	Contact Viper Distributor
	Bad vacuum motor	Contact Viper Distributor
Short run time	Carbon brushes worn out	Contact Viper Distributor
	Batteries need to be charged	Charge batteries (see Battery Charging)
	Batteries need maintenance	See Battery Maintenance in this manual
	Bad cell in battery(s)	Replace batteries
Little or no solution flow	Bad charger	Replace charger
	Bad solution switch	Contact Viper Distributor
	Clogged solution solenoid	Contact Viper Distributor
	Clogged solution filter	Remove filter and clean
	Solution line obstructed	Remove solution line and clean
Poor water pick up	Solution flow adjustment knob in need of adjustment	Increase flow by twisting solution adjustment knob to the right. Decrease flow by twisting solution adjustment knob to the left.
	Squeegee clogged	Clean debris off squeegee with damp towel
	Squeegee blades worn	Install new squeegee blades
	Squeegee not mounted correctly	Confirm that the squeegee assembly is securely fastened to the machine and not loose fitting.
	Vacuum hoses have a hole or are loose	Check hose connections and make sure they are firm. Replace hose if damaged.
	Vacuum hose may be clogged	Check hose for debris and remove any clog.
	Drain hose stopper is loose	Tighten drain plug.
	Batteries need to be charged	Charge batteries (see Battery Charging)
	Vacuum motor is loose	Tighten vac motor mounting screws. Do not overtighten or damage will occur.
	Recovery tank lid is loose	Confirm the clear recovery tank lid is securely in place.
	Recovery tank inlet hole is clogged	Drain recovery tank and tilt tank on side. Check the inlet hole for debris and remove debris.
	Recovery tank is full	Drain recovery tank.
	Float shut off is clogged	Remove float shut off from inside recovery tank and remove any debris.

PARTS LIST

FANG20HD - SOLUTION TANK ASSEMBLY

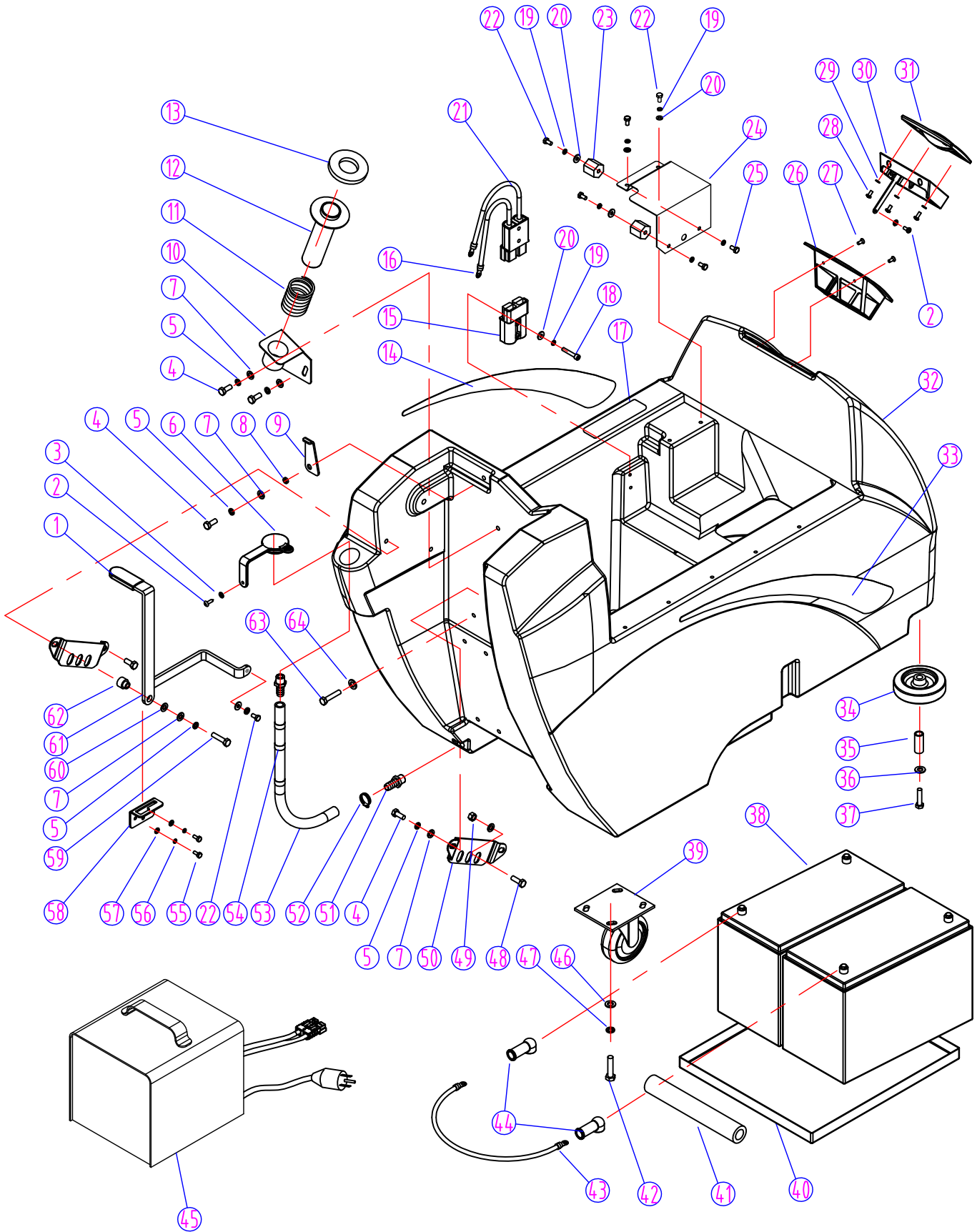

FANG20HD - SOLUTION TANK ASSEMBLY

DIA NO	PART NUMBER	DESCRIPTION	NO REQ'D
1	VF81405	GRIP,HANDLE	1
2	VA13477	SCREW, SELF-TAPPING, ST, M4 X 16	3
3	VV13664	WASHER,PLAIN, M4 X M12 X 1	1
4	VV13604	SCREW, M8 X 20	6
5	VF13519	WASHER,LOCK, M5 X M11 X 28	6
6	VF82154	PLUG,EXPANSION	1
7	VF13535	WASHER,PLAIN, M8 X M20 X 2	8
8	VF81406	BUSHING	1
9	VF81404	SUPPORT,RECOVERY TANK	1
10	VF82029	BRACKET,VAC TUBE	1
11	VF82032	SPRING	1
12	VF82030	ADAPTER,TUBE	1
13	VF82031	GASKET,TUBE ADAPTER	1
14	VF82070	LABEL,LEFT	1
15	VF81306	CONNECTOR, 175A	2
16	VF81747	WIRE, #6 X 750	1
17	VF82123	DECAL	1
18	VF13633	SCREW, M6 X 35	2
19	VV13607	WASHER,LOCK, M6	8
20	GT13032	WASHER,PLAIN, M6 X M16 X 1.5	6
21	VF81748	WIRE, #6 X 750	1
22	VF13495	SCREW, M6 X 16	4
23	VF81715	STANDOFF	2
24	VF82067	BRACKET	1
25	VF14232	SCREW, M6 X 10	2
26	VF82078	SCREEN,FILL	1
27	VF13543	SCREW, SELF-TAPPING, ST, M4 X 16	2
28	VF13544	SCREW, SELF-TAPPING, ST, M4 X 10	6
29	VA13483	WASHER,PLAIN, M4 X M9 X 0.8	7
30	VF82081	PLUG,FILL SCREEN	1
31	VF82079	COVER,FILL SCREEN	1
32	VF82801	SOLUTION TANK	1
33	VF82071	LABEL,RIGHT	1
34	VF99001	WHEEL, 4"	2
35	VF83129	BUSHING	2
36	VF13514A	WASHER,PLAIN, M8 X M16.5 X 1	2
37	VF13635	SCREW, M8 X 50	2
38	BAT195I	BATTERY,12V,195AMP HOUR	2
39	VF83111	CASTER, 4"	2
40	VF83140	TRAY,BATTERY	1
41	VF82072A	SPACER,BATTERY	1
42	VF13634	SCREW, M10 X 30	8

FANG20HD - SOLUTION TANK ASSEMBLY

DIA NO	PART NUMBER	DESCRIPTION	NO REQ'D
43	VF82403	CABLE,BATTERY	1
44	VF81724	CAPS,BATTERY,BLACK	2
	VF81724R	CAPS,BATTERY,RED	2
45	CHRGR18	CHARGER,24V,18AMP	1
46	VF13537	WASHER,PLAIN, M10 X M26 X 2	8
47	VF13518	WASHER,LOCK, M10	8
48	VF14234	SCREW, M8 X 16	2
49	VF13513	NUT, M8	2
50	VF81408	PLATE,LOCK	2
51	VF81416	HOSE BARB	2
52	VF82161	CLAMP (16-25)	1
53	VF81123	TUBING	1
54	VF82306A	KIT,LABEL,MARKERS	1
55	VF14230	SCREW, M5 X 15	3
56	VV13601	WASHER,LOCK, M5	3
57	VF13532	WASHER,PLAIN, M5 X M11 X 2	3
58	VF81202	PLATE,SQGE,LOCK	1
59	VF14235	SCREW, M8 X 35	1
60	VF48216	WASHER,LOCK, M12.7	1
61	VF83124	HANDLE,SQGE,LIFT	1
62	VF82050A	BUSHING	1
63	VF14248	SCREW, M8 X 100	1
64	VA13516	WASHER,PLAIN, M10 X M30 X 1.5	1

PARTS LIST

FANG20HD - RECOVERY TANK ASSEMBLY

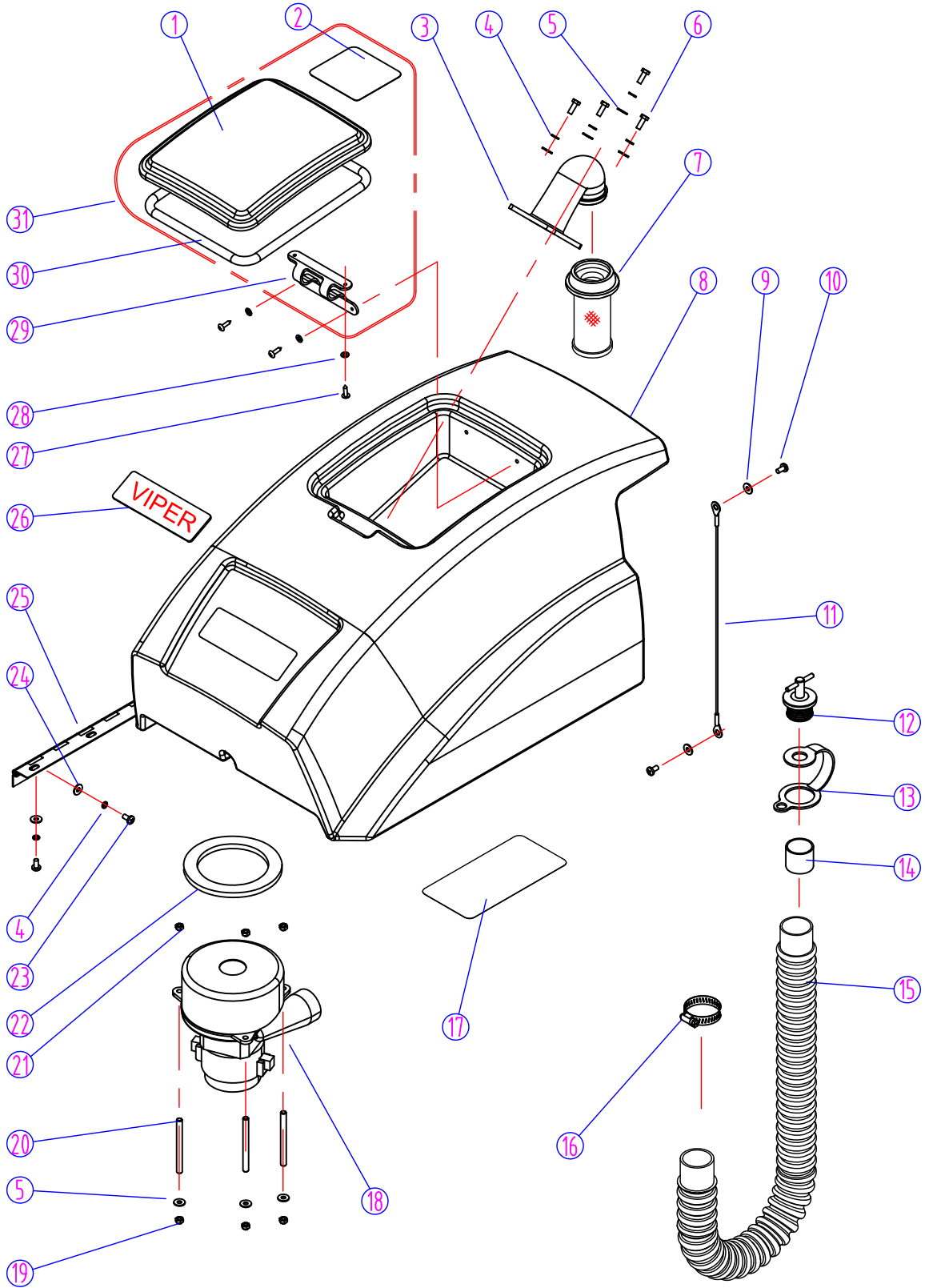

PARTS LIST

FANG20HD - BRUSH LIFT / DRIVE ASSEMBLY

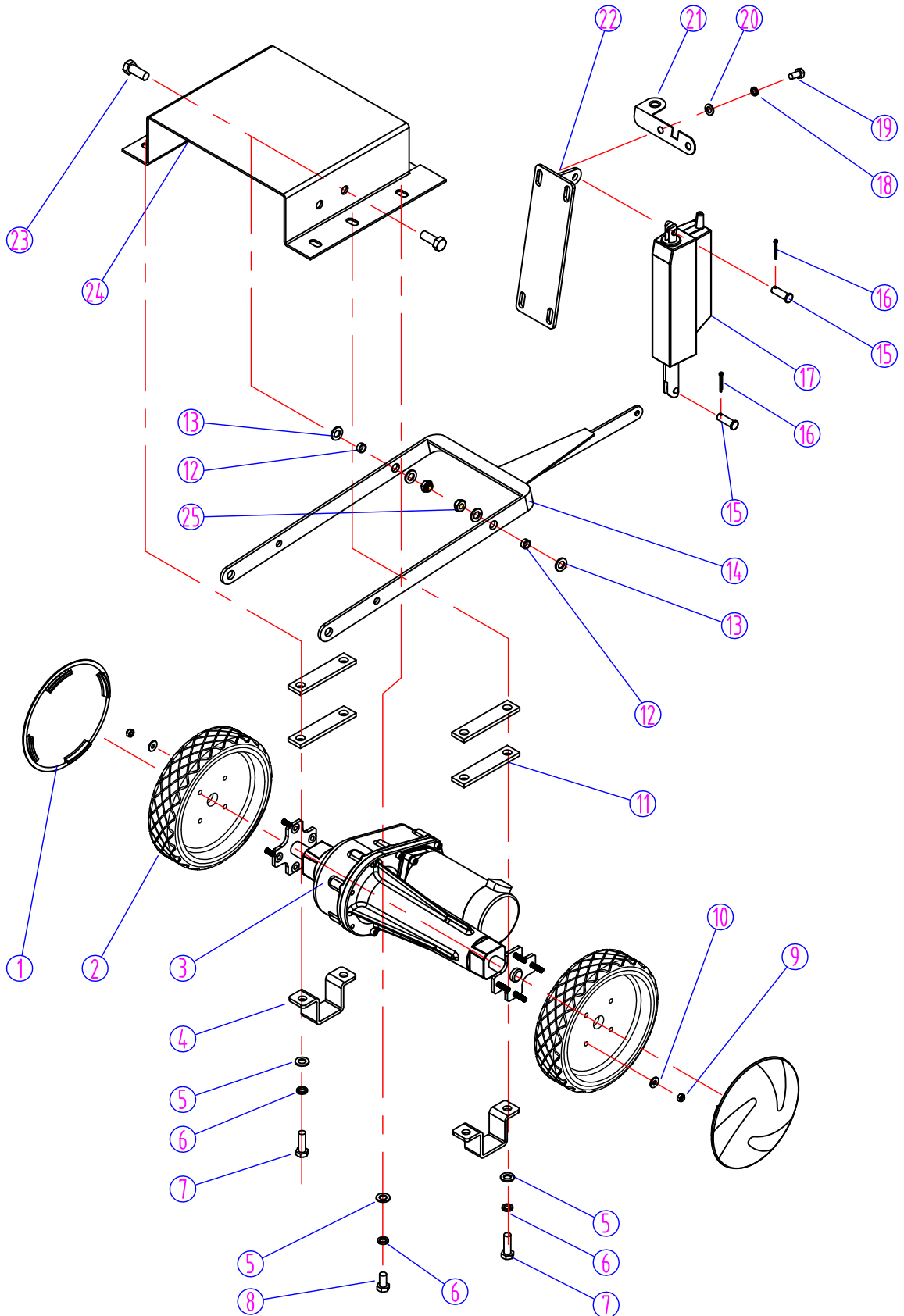

PARTS LIST

FANG20HD - BRUSH / PAD DRIVE ASSEMBLY

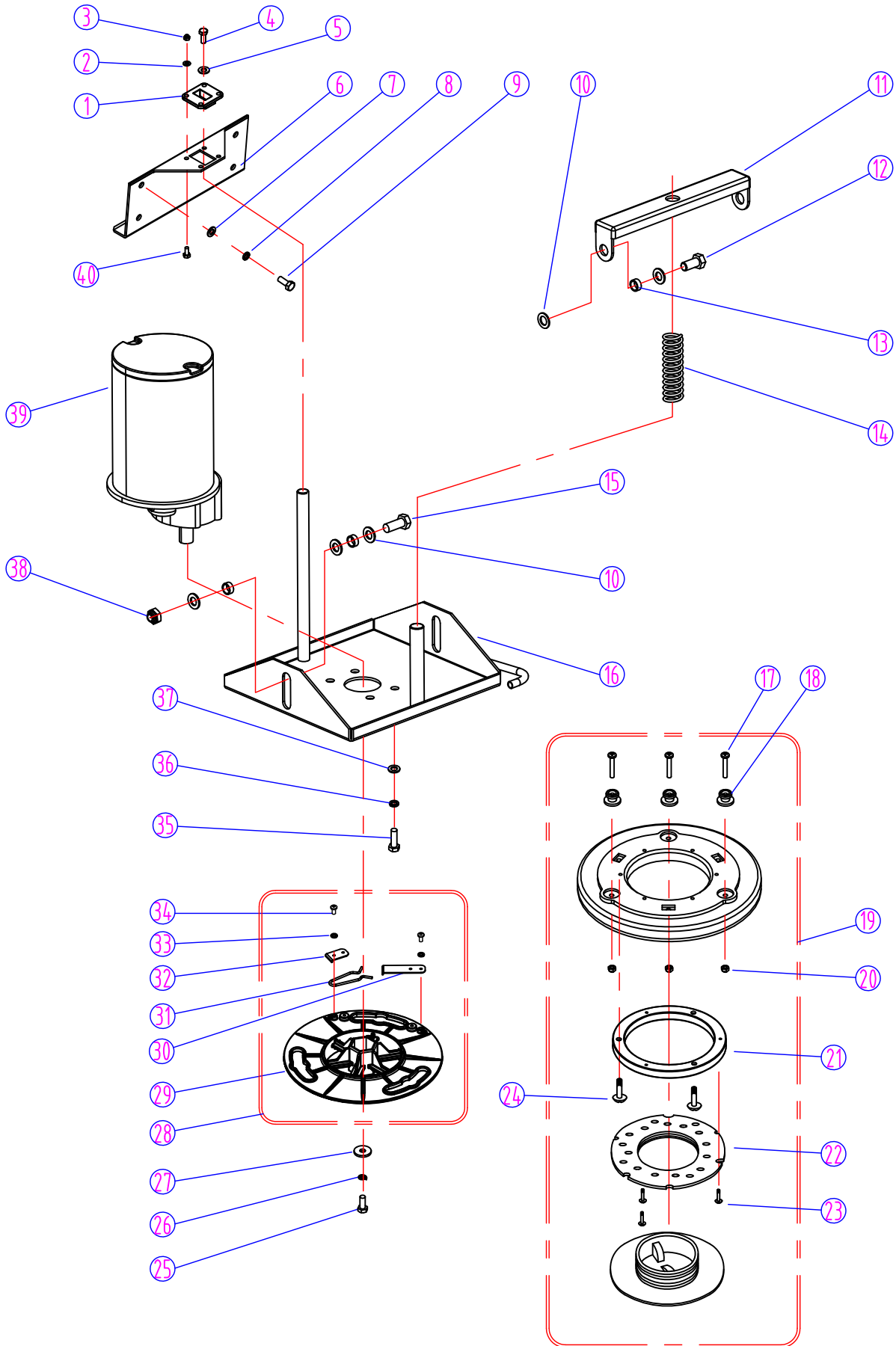

FANG20HD - BRUSH/PAD DRIVE ASSEMBLY

DIA NO	PART NUMBER	DESCRIPTION	NO REQ'D
1	VF83112A	BLOCK,GUIDE	1
2	VA13400	WASHER,PLAIN, M5 X M11 X 1	4
3	GT13022	NUT,LOCK, M5	4
4	VF14234	SCREW, M8 X 16	1
5	VF13542	WASHER,PLAIN, M8 X M26 X 2	1
6	VF83116A	SUPPORT PLATE,SKIRT	1
7	VF13535	WASHER,PLAIN, M8 X M20 X 2	4
8	VF13519	WASHER,LOCK, M8	4
9	VV13604	SCREW,M8X20	4
10	VF13538	WASHER,PLAIN,M12XM22X2	10
11	VF82805	BRACKET,SPRING	1
12	VF14247	SCREW,M12X25	2
13	VF82016A	BUSHING	6
14	VF83117	SPRING	1
15	VF14238	SCREW,M12X30	2
16	VF82804	BRACKET,MOTOR MOUNT	1
17	VF14225A	SCREW,M6X40	3
18	VF83133	STUD	3
19	VF82057	PAD DRIVER, 19" (FANG20T)	1
20	VF13502	NUT,LOCK, M6	3
21	VF83118	SPACER	1
22	VF99003A	BIG MOUTH	1
23	VA13484	SCREW,SELF-TAPPING,ST, M4 X 12	3
24	MF-VF002-4A	SCREW,SELF-TAPPING, 1/4" - 1"	3
25	VF14241	SCREW, 5/16" - 1"	1
26	VV20298	WASHER,LOCK, 5/16"	1
27	VF82058	WASHER	1
28	VF83130A	PLATE, DRIVE, ASSY	1
29	VF83130	PLATE,DRIVE	1
30	VF83134	STOP,DRIVE RELEASE	1
31	VF83132	SPRING	1
32	VF83131	CLAMP,BRUSH PLATE	1
33	VV13601	WASHER,LOCK, M5	4
34	VF13545	SCREW,SELF-TAPPING,ST,M5 X 10	4
35	VF14242	SCREW, 3/8" - 1"	4
36	VV13620	WASHER,LOCK, 3/8"	4
37	VF13537	WASHER,PLAIN,M10 X M26 X 2	4
38	VF13501	NUT,LOCK,M12	2
39	ZD45000	BRUSH MOTOR,24VDC, .75HP	1
	ZD45407	KEY, 6.35 X 25	1
40	VF14230	SCREW, M5 X 15	4

PARTS LIST

FANG20HD - SOLUTION CONTROL ASSEMBLY

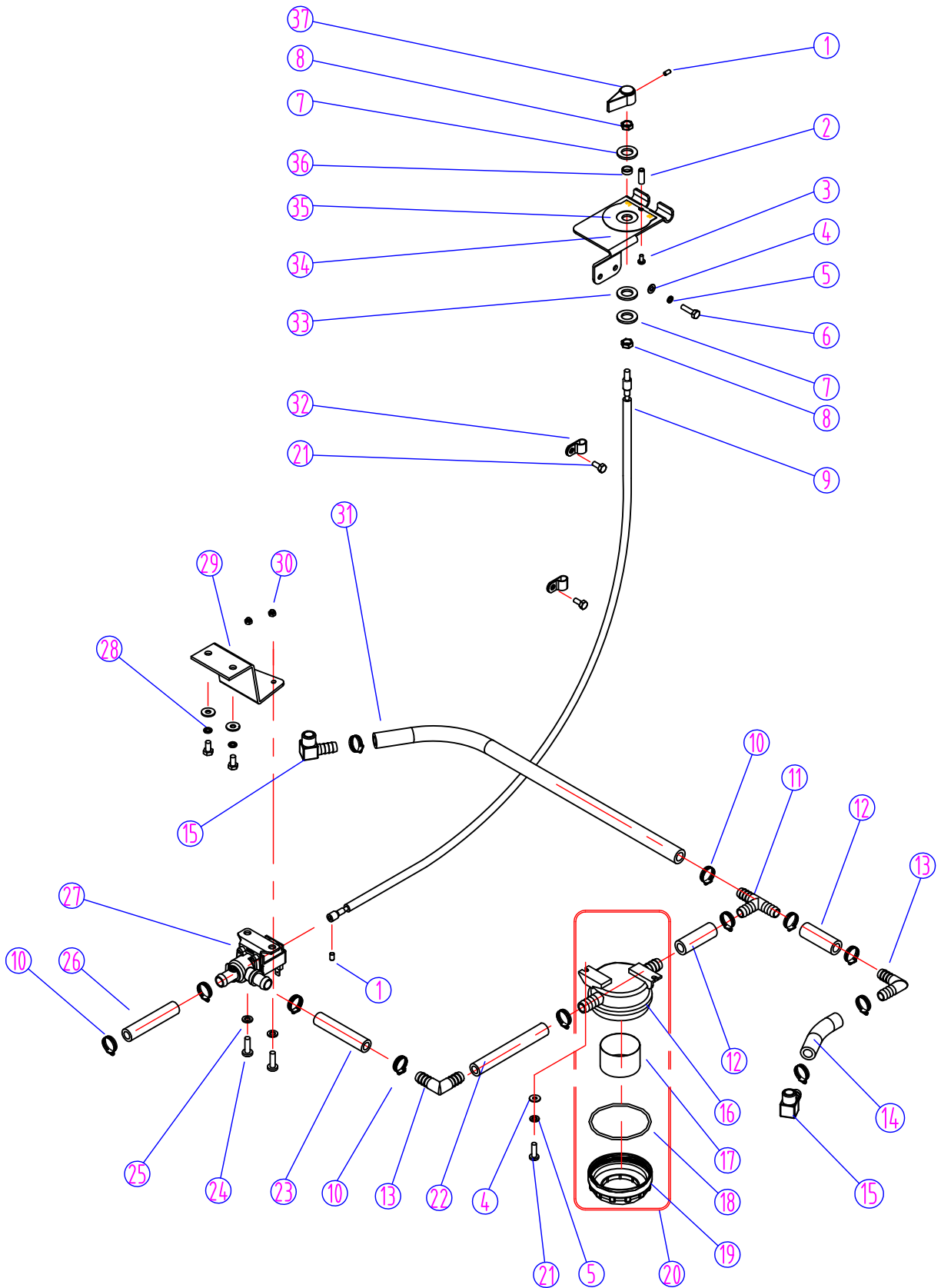

FANG20HD - SOLUTION CONTROL ASSEMBLY

DIA NO	PART NUMBER	DESCRIPTION	NO REQ'D
1	VF14245	SCREW, M5 X 6	2
2	VF82036	SHAFT	1
3	VV13650	SCREW, M4 X 10	1
4	VF13532	WASHER,PLAIN, M5	4
5	VV13601	WASHER,LOCK, M5	4
6	VF14230	SCREW, M5 X 15	2
7	VF13536	WASHER,PLAIN, M9.8 X M16 X 1	2
8	VF82075	NUT, 3/8"	2
9	VF83121	CABLE,SOLENOID	1
10	VF82148	CLAMP, 16mm	14
11	VF82040	HOSE BARB,TEE	1
12	VF81134	TUBING, 50mm	2
13	VF82042	ELBOW	2
14	VF81124	TUBING, 115mm	1
15	VF81403	ELBOW,SOLUTION TANK	2
16	VF80112	SEAT,FILTER	1
17	VF80113	SCREEN,FILTER	1
18	VF82139	"O"RING, M2.65 X M64.8	1
19	VF80111	COVER,FILTER	1
20	VF80111A	KIT,FILTER	1
21	VV20509	SCREW, M5 X 10	5
22	VF81125	TUBING, 200mm	1
23	VF81126	TUBING, 80mm	1
24	VF13495	SCREW, M6 X 16	4
25	VF13533	WASHER,PLAIN, M6 X M16 X 2	4
26	VF81127	TUBING, 65mm	1
27	VF82033-24	SOLUTION VALVE SOLENOID,24VDC	1
28	VV13607	WASHER,LOCK, M6	2
29	VF83120	BRACKET,SOLENOID	1
30	VF13502	NUT,LOCK, M6	2
31	VF81128	TUBING, 320mm	1
32	VF81118	CLAMP	2
33	VF13540	WASHER,WAVE, M12	1
34	VF82037	BRACKET,DRAIN HOSE & VALVE	1
35	VF82069	LABEL,VALVE	1
36	VF82074	BUSHING	1
37	VF82038	KNOB,VALVE ADJUST	1

PARTS LIST

FANG20HD - BRUSH SKIRT ASSEMBLY

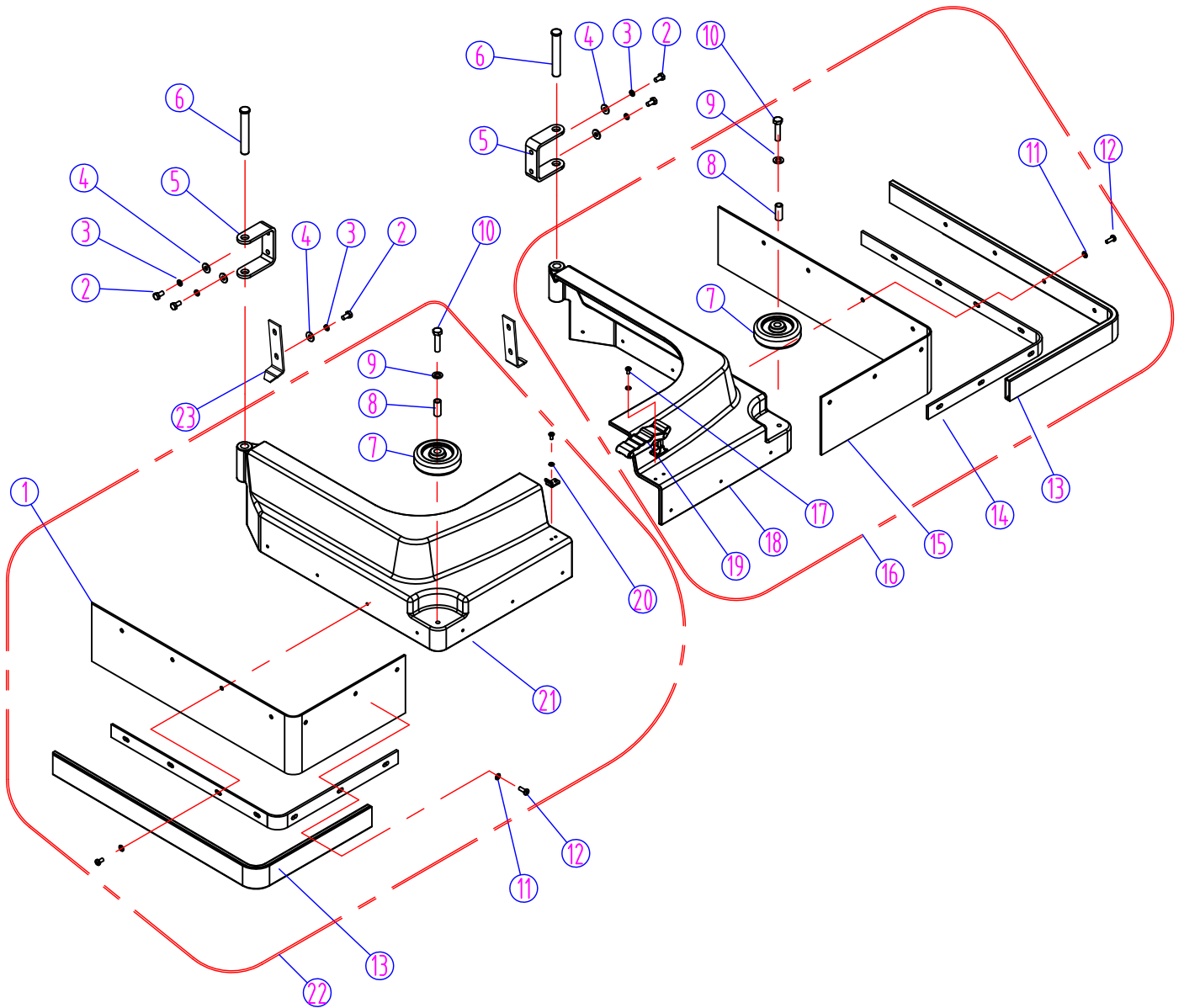

PARTS LIST

FANG20HD - CONTROL HOUSING

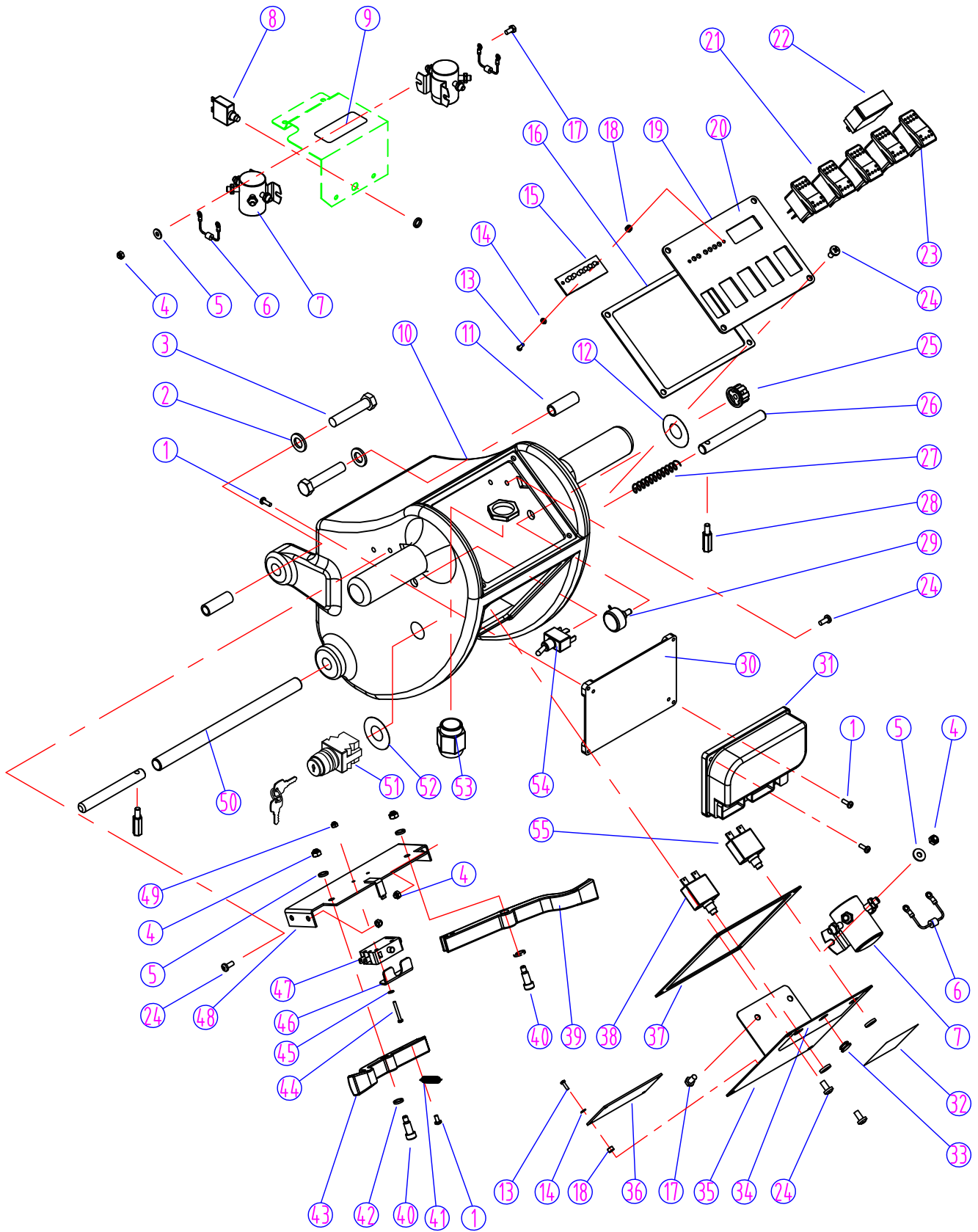

FANG20HD - CONTROL HOUSING

DIA NO	PART NUMBER	DESCRIPTION	NO REQ'D
1	VF13491	SCREW, M4 X 12	7
2	VF14122	WASHER,PLAIN, M10 X M20 X 2	2
3	VF14121	SCREW, M10 X 65	2
4	VF13502	NUT,LOCK, M6	10
5	GT13032	WASHER,PLAIN, M6	6
6	VF81781	DIODE, 400V	3
7	VF81726	SOLENOID, 24V	3
8	VF81735	BREAKER,CIRCUIT, 25 AMP	1
9	VF83149	LABEL,CIRCUIT BREAKER	1
10	VF82301	HOUSING,CONTROL	1
11	VF81713	BUSHING	2
12	VF82305	LABEL,SPEED CONTROL	1
13	VF14078	SCREW,M3 X 10	6
14	VA50477	WASHER,PLAIN, M3 X M10 X 1	6
15	VF81718	LIGHTS,BATTERY CAPACITY	1
16	VF82313	GASKET	1
17	VF13495	SCREW, M6 X 16	4
18	VF81719	SPACER	6
19	VF83137A	PANEL,SWITCH (24")	1
20	VF82811	LABEL,SWITCH (FANG 20HD)	1
21	VF81721	SWITCH,LIGHTED ROCKER	4
22	VF81727	GAUGE,BRUSH PRESSURE	1
23	VF81725	SWITCH,BRUSH LIFT	1
24	VF14200	SCREW, M6 X 16	12
25	VF81730	KNOB,SPEED CONTROL	1
26	VF81709	PIN,HANDLE LOCK	2
27	VF81716	SPRING	1
28	VF81710	PIN,HANDLE ADJUSTMENT	2
29	VF81729	POTENTIOMETER, 4.7K	1
30	VF82316	PLATE	1
31	VF81739-20T	SPEED CONTROL,BOARD	1
32	VF82812	SERIAL TAG (FANG 20HD)	1
33	GV40239	COVER	1
34	VF83148	LABEL,CIRCUIT BREAKER	1
35	VF82303	PANEL,CONTROL HOUSING	1
36	VF81703	BATTERY CAPACITY CONTROL,BOARD	1
37	VF82312	GASKET	1
38	VF99012	BREAKER,CIRCUIT, 12 AMP	1
39	VF82107B	HANDLE,RIGHT	1
40	VF81711	BOLT,SHOULDER, M8 X 15 X M6	2
41	VF81712	SPRING	1
42	VF13514A	WASHER,PLAIN, M8 X M16.5 X 1	2
43	VF82106B	HANDLE,LEFT	1
44	VF14212	SCREW, M3X25	2
45	VF13511	WASHER,TEETH, M3	2
46	VF82327	GUIDE,SWITCH	1
47	VF99023	SWITCH ASSY	1
48	VF81707	BRACKET,SWITCH (24")	1
49	VV13652	NUT,LOCK, M3	2
50	VF81714	TUBE,HANDLE,ADJUSTMENT	1
51	VF82153	SWITCH,KEY	1
52	VF82160	LABEL,KEY SWITCH	1
53	VF81744	STRAIN RELIEF,CORD	1
54	VF81722	SWITCH,TOGGLE	1
55	VF81734	BREAKER,CIRCUIT,35AMP	1

PARTS LIST

FANG20HD - SQUEEGEE ASSEMBLY

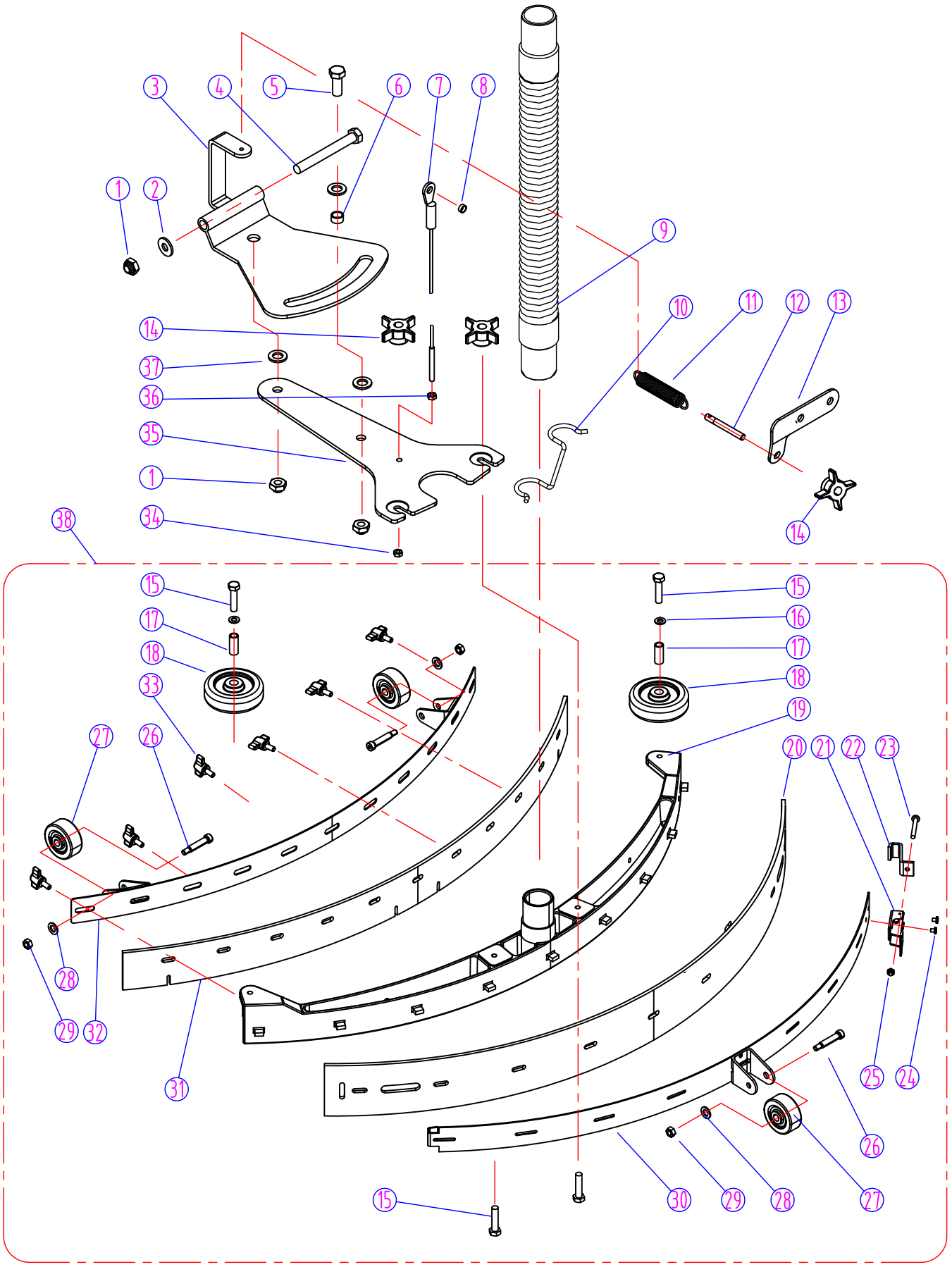

FANG20HD - SQUEEGEE ASSEMBLY

DIA NO	PART NUMBER	DESCRIPTION	NO REQ'D
1	VF13501	NUT,LOCK, M12	3
2	VF13538	WASHER,PLAIN, M12 X M26 X 2	1
3	VF83122	MOUNT,PIVOT	1
4	VF13637	SCREW, M12 X 130	1
5	VF14238	SCREW, M12 X 30	2
6	VF82016A	BUSHING	2
7	VF81243	CABLE,SQGE,LIFT (24")	1
8	VF82112	BUSHING	1
9	VF81203A	HOSE	1
10	VF83150	HOLDER,"U" HOSE	1
11	VF83144	SPRING	1
12	VF82047	SHAFT	1
13	VF83125	BRACKET,SPRING	1
14	VF81210	KNOB, M8	3
15	VF14236	SCREW,M8 X 40	4
16	VF13514A	WASHER,PLAIN, M8 X M16.5 X 1	2
17	VF82055	BUSHING	2
18	VF82013	WHEEL, 3"	2
19	VF82116	HOUSING,SQUEEGEE (FANG 20)	1
20	VF82063	BLADE, SQUEEGEE, REAR (PU)	1
	VF82119	BLADE,SQUEEGEE,REAR (NEOPRENE)	1
21	VF81218	LATCH,HOOD	1
22	VF81209	HOOK,REAR SQUEEGEE BACKUP ADJUSTMENT	1
23	VF14310	SCREW, M5 X 70	1
24	VF81208	RIVET, M4 X 5	2
25	GT13022	NUT,LOCK, M5	1
26	VF81222	BOLT,SHOULDER, 5/16" X 1.25"	3
27	VF81219	WHEEL, 2"	3
28	VF13535	WASHER,PLAIN, M8 X M20 X 2	3
29	VV20203	NUT,LOCK, 5/16"	3
30	VF82120	BACKUP STRIP,SQUEEGEE,REAR	1
31	VF82062	BLADE,SQUEEGEE,FRONT,(PU)	1
	VF82117	BLADE,SQUEEGEE,FRONT,(NEOPRENE)	1
32	VF82118	BACKUP STRIP,SQUEEGEE,FRONT	1
33	VF82121	KNOB, M6	6
34	VF13502	NUT,LOCK, M6	1
35	VF83123	BRACKET,SQGE,MOUNT	1
36	VF13521	NUT, M6	1
37	VF13539	WASHER,PLAIN, M12 X M32 X 2	4
38	VF82908A	SQUEEGEE ASSY	1

WIRING DIAGRAM FOR FANG 20HD

